

Be2K-Plus Automatic Mains Failure Installation Manual

The information in this document may be subject to change without notice.

No part of this document may be copied or reproduced in any form or any means without the prior written consent of Bernini Design Company. Bernini Design assumes no responsibility for any errors which may appear in this instruction manual or in the wiring diagrams. Although Bernini Design has taken all possible steps to ensure that the User Manual is complete, bug free and up-to-date, we accept that errors may occur.

Customer Support BERNINI DESIGN SRL ITALY

e-mail: bernini@bernini-design.com mobile: ++40 721 241 361. Tel:++39 0386-31445

Warranty

Bernini Design SRL (hereinafter "BD") warrants that Be2K-Plus shall be free from defect in material or workmanship for a period of 3 years from the BD delivery date. BD shall, at its discretion, repair or replace the product without charge. BD shall return the Be2K-Plus to the buyer with the Default parameters at no extra charge. The buyer shall furnish sufficient information on any alleged defects in the product, so as to enable BD to determine their cause and existence. If the Be2K-Plus is not defective, or the product is defective for reason other than covered by this warranty, the buyer will be charged accordingly. This warranty shall not apply if the Be2K-Plus has not been used in accordance with the User Manual and other operating instruction, particularly if any defects are caused by misuse, improper repair attempts, negligence in use or handling. This purchase is non-refundable.

This equipment complies with the EMC protection requirements



!! WARNING !!

High voltage is present inside the Be2K-Plus. To avoid electric-shock hazard, operating personnel must not remove the protective cover. Do not disconnect the grounding connection. The Be2K-Plus can start the engine at anytime. Do not work on equipment, which is controlled by the Be2K-Plus. When servicing the engine, disconnect the battery and battery charger. We recommend that warning signs be placed on equipment indicating the above.

Alphabetic index

<p><i>Air conditioner monitoring</i>7.03,13.09, 12.11B <i>Alternator Failure</i> 12.02B,13.04 <i>Alarms</i>..... 13.0, 5.05 <i>Alarm (Horn) TIME-OUT</i>..... 12.06 <i>Alarm bypass (after start)</i> 12.03A <i>Alarm 1-2</i> 13.02, 12.10 <i>Auto mode</i>2.3 <i>Automatic Periodic Test</i>.....7.00 <i>Auxiliary Temperature</i>..... 12.03C</p> <p><i>Battery (engine) Alarms</i> 13.03 <i>Battery (telecom) Alarms</i>7.03 <i>Belt break</i> 13.03</p> <p><i>Choke, control</i>..... 12.03A <i>Calibration</i>5.07 <i>CAN BUS</i> 12.12, 13.01 <i>Characteristics</i>..... 16.0 <i>Charger Alternator/Failure</i> 14.0/13.03 <i>Clock setting</i>6.00 <i>Clock setting, error</i>6.00 13.01 <i>Clear the memory</i>9.00 <i>Contactors (use)</i>2.21 <i>Connectors, Plugs</i>22.0 <i>Connections list</i>.....22.0 <i>Configurable inputs</i> 12.10 <i>Configurable outputs</i> 12.11 <i>Cooling down time</i>..... 12.03A <i>Current/Warning/SD</i>..... 12.02A,13.04 <i>Current measurements</i>.....5.01 <i>Crank timing</i>..... 12.03A <i>Current Transformer</i>..... 12.02B</p> <p><i>Defaults</i>..... 12.13 <i>Dimensions</i>21.0 <i>Display & Messages</i>3.1, 4.0 <i>Droop settings</i> 12.04 <i>Dual set Generator control</i>..... 18.20</p> <p><i>Earth Failure</i>..... 12.02B, 13.04 <i>Engine Running</i> 14.0 <i>Engine Alarms Bypass</i>..... 12.03A <i>Engine Parameters</i> 12.03A-B-C-D <i>Energy counter (clear)</i>.....9.00 <i>Emergency (Alarm2)</i>..... 12.10 <i>Event history</i>.....5.06 <i>Events (clear)</i>.....9.00</p> <p><i>Fail to Start /Stop</i>..... 13.03 <i>Front Panel</i>..... 1.0 Figure 1 <i>Front Panel Emergency</i>..... 13.02A <i>Frequency (Mains/Gen)</i> 12.01, 12.02 <i>Fuel Level & Alarms</i> 12.05, 13.06</p>	<p><i>Generator control</i> 12.02 A-B <i>Generator Voltage/Hz</i>..... 12.02A,13.04 <i>Generator Failure</i> 12.02B,13.04 <i>Glow Plugs</i>..... 12.03</p> <p><i>Hour Counter</i> 12.06 <i>Horn Programming</i> 12.06</p> <p><i>Idle time</i> 12.04 <i>Idle speed</i> 12.04 <i>Inputs (Programmable)</i>..... 12.10 <i>Inputs 1--5 Alarm</i>..... 13.02</p> <p><i>kW,kVA (Max,Min)</i> 5.03, 12.02B,13.04 <i>KM-KG Failure</i> 13.04</p> <p><i>Language selection</i> 11.0 <i>Lamp Test, LEDs</i> 3.0 <i>Low Battery voltage</i> 13.03 <i>Locked by remote control</i> 13.02B</p> <p><i>Mains Failure/Restore</i> 12.01 <i>Maximum run time</i>..... 13.08, 7.02 <i>Mains Simulated</i>..... 12.10 <i>Measurements</i> 5.0 <i>Menu (parameter)</i> 12.00 <i>Maintenance Timers</i>..... 8.0, 13.08 <i>Memory and Memory Error</i>..... 9.00, 13,01 <i>Memory (clear)</i>..... 9.00 <i>Manual mode</i> 2.20 <i>Modem settings</i> 10.02</p> <p><i>NFPA-110</i> 12.06, 18.30</p>
---	--

<p>OEM Password9.13 Oil pressure12.03B,13.07 Oil temperature page12.03B Outputs (programmable).....12.11 Operating modes2.0 Over Current.....12.02A Over Speed.....12.04,13.03 Overload (option [29]).....12.10,13.04 Over Frequency/Voltage.....12.02A,13.04</p> <p>Panel emergency13.02 Parameters4.00, 12.00 Parameter error.....13.01 Parameters reading9.00 Password(s)4.00, 9.10, 9.13 Periodic test (automatic).....7.00 Pick-up (error).....12.04, 13.03 Program, Programming.....12.00 Pre Glow12.03A Power Supply.....16.00 Push buttons.....1.0 Pump fuel (tank).....12.05,13.06</p> <p>Rest time.....12.03A Read Parameters4.00, 12.00 Reverse Power.....12.02B, 13.04 Rental settings7.00, 13.08 Remote Engine testTable 12.10 [25] Remote Lock13.02B Rental Genset testTable 12.10 [26] Run Timeout.....7.02, 13.08 R.P.M......12.04 RS48510.01</p>	<p>Settings (Parameters)12.00 Shutdowns (alarms).....13.00 Speed settings.....12.04 Speed indications.....5.04 Sensors12.07-08-09 Service & Maintenance8.00 Serial number10.00 Sequence Error.....13.04 Single Phase operation.....18.10 Specifications16.00 Software upgrade17.00 Short circuit.....13.04 Start.....2.20 Start Attempts.....12.03A Starting Failure.....13.03 Stop, Stop solenoid.....12.03A</p> <p>Tank Empty.....12.05 TCP-IP10.0 Temperature alarms12.03B, 13.05 Telecom application.....7.02 Test, Remote Test22.00 Test (periodic) Test Failure13.01 Test mode2.40 Terminal description22.00 Tooth count.....12.04 Transformer, Current12.02B Troubleshooting.....15.00</p> <p>Under Voltage / Frequency12.02A, 13.04 Under Speed13.03 User password9.13</p> <p>Voltage measurements5.01, 5.02</p> <p>Warm-Up time.....12.03A Wiring diagram20.00 Warnings (alarms).....13.00</p>
--	--

Be2K-Plus OEM's Manual - Contents

1.0 Introduction	page 5
2.00 Selecting an Operational Mode	page 6
2.10 OFF mode.....	page 7
2.20 MANUAL mode.....	page 7
2.21 MANUAL control of the contactors	page 7
2.30 AUTO mode.....	page 8
2.40 TEST mode.....	page 8
3.0 LEDs indicators	page 8
3.01 LED Display description	page 9
4.0 GRAPHIC DISPLAY	page 9
5.0 Measurements & Events	page 9
5.01 Generating Set.....	page 10
5.02 Mains	page 10
5.03 Power & Energy.....	page 10
5.04 Engine & Fuel	page 10
5.05 Alarm Messages.....	page 11
5.06 Event History	page 12
5.07 Calibration.....	page 12
5.08 Calibration Table.....	page 13
6.0 Clock Settings	page 13
7.0 Test & Rental Program	page 14
8.0 Maintenance Timers	page 15
9.0 Memory & Passwords	page 15
10.0 Communications & Serial interfaces	page 16
10.01 Node address	page 16
10.02 Modem & Phonebook.....	page 17
10.03 TCP-IP settings.....	page 17
11.0 Display & Languages	page 17
12.0 Programming & Automation Parameters ...	page 18
12.01 Mains Control.....	page 19
12.02 Generator Parameters.....	page 20
12.03 Engine Parameters.....	page 21
12.04 Speed Parameters.....	page 23
12.05 Fuel Settings.....	page 23
12.06 Miscellaneous.....	page 24
12.07 Oil sender Table (Ohm-mA-V).....	page 24
12.08 Coolant sender Table (Ohm-mA-V).....	page 24
12.09 Fuel sender Table (Ohm-mA-V)	page 24
12.10 Configurable Inputs	page 25
12.11 Configurable Outputs.....	page 26
12.12 Can Bus settings.....	page 27
12.13 Restore Default.....	page 27

13.0 Alarms, Warnings & Shutdowns page 28

13.01 Clock & Periodic test alarm page 28

13.02 Emergency alarm & Shutdowns..... page 28

13.03 Miscellaneous engine alarms..... page 29

13.04 Alternator & Contactors alarms page 29

13.05 Temperature alarms page 30

13.06 Fuel Level alarms..... page 30

13.07 Oil Pressure alarms..... page 31

13.08 Maintenance and Rental alarms..... page 31

14.0 Engine Running /charger alternator page.. page 31

15.0 Troubleshooting guide..... page 32

15.01 Testing the inputs..... page 33

15.02 Testing the pushbuttons..... page 33

15.03 Testing the outputs page 34

15.04 Testing the analogue input..... page 34

15.05 Testing the measurements page 34

16.0 General Specifications page 35

17.0 Software Upgrades & Revisions page 35

18.0 Application Notes page 36

19.0 Panel builder notes..... page 38

20.0 Typical application wiring..... page 39

21.0 Rear view and Dimensions page 40

22.0 Terminal description page 41, 42

SECTION 1.0 - INTRODUCTION

!! WARNING !!

The Be2K-Plus can start the engine at anytime. Do not work on equipment, which is controlled by the Be2K-Plus. When servicing the engine, disconnect the battery and battery charger. We recommend that warning signs be placed on equipment indicating the above.

The Be2K-Plus integrates a 3-Phase Automatic Mains Failure (A.M.F.) module, an Automatic Transfer Switch controller (A.T.S.) and a Generating Set controller. The Be2K-Plus provides visual indication by means of LEDs and Displays for all parameters and alarms. The Be2K-Plus features programmable settings and complies with NFP110 CAN/CSA-C282-M89 regulations. It provides RS485, RS232 and CAN-BUS (J1939) interfaces. Figure 1 illustrates the layout of the front panel.

Figure 1: Front Panel layout

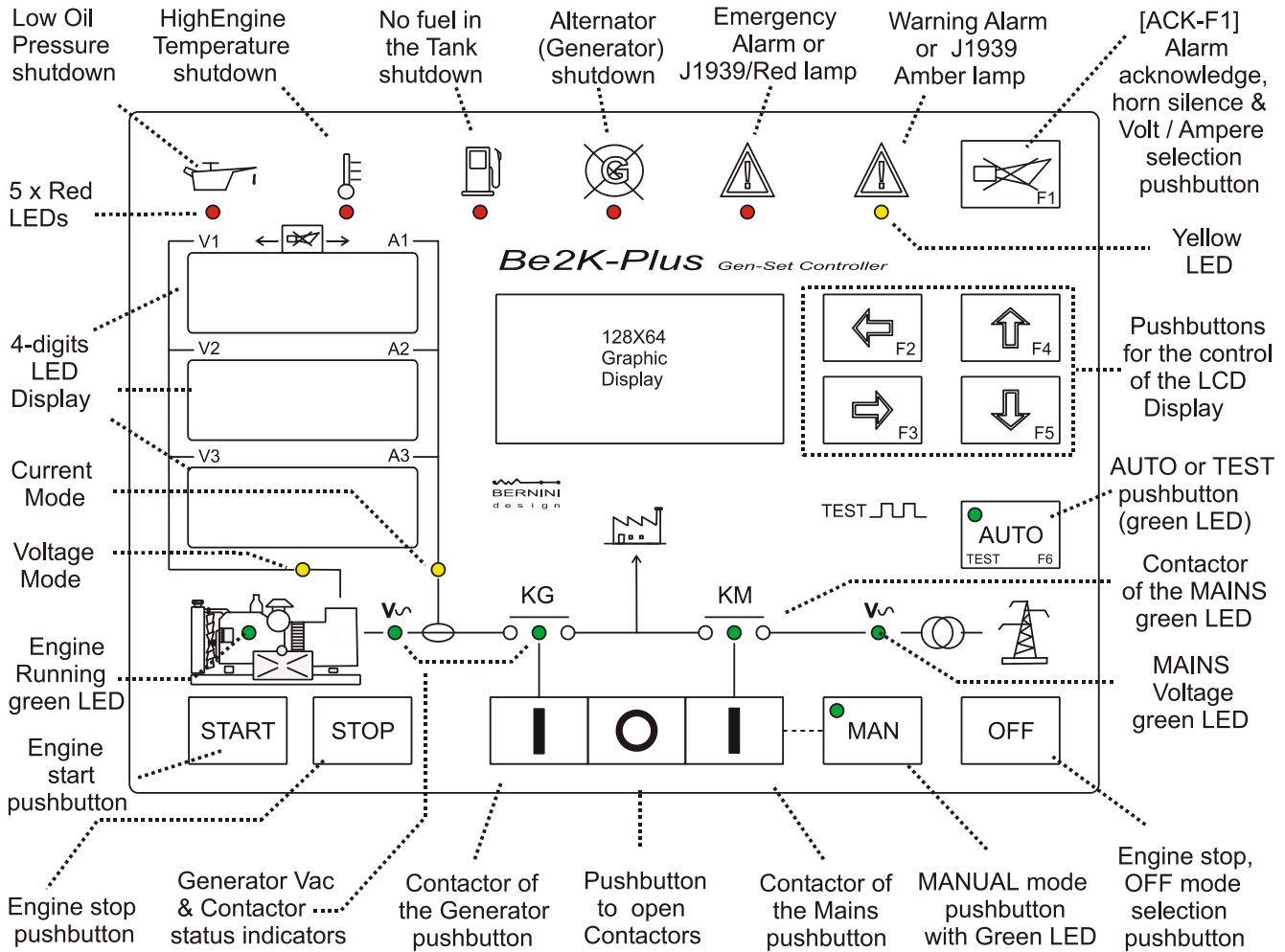

SECTION 2.0 - SELECTING AN OPERATIONAL MODE

The mode of operation is selected by pushbuttons and indicated by means of green LEDs:

<p>MANUAL Mode green LED=ON</p> <p>Pushbutton</p>	<p>TEST Mode green LED=blinks</p> <p>Pushbutton</p>	<p>TEST Mode green LED=blinks</p> <p>Pushbutton</p>	<p>AUTO Mode green LED=on</p> <p>Pushbutton</p>	<p>NOTE: If the Be2K-Plus was in TEST or AUTO prior to power down, when you switch on the power supply, the Be2K-Plus enters the AUTO mode. In the other cases, the Be2K-Plus will enter the OFF mode.</p> <p><u>The following sections describe the modes of operation</u></p>
---	---	---	---	---

2.10 OFF mode

Push the [OFF] pushbutton: you clear the fault alarms and you are allowed to program the parameters (sections 9.00 & 12.0). The Display and LEDs are turned off; a dot on the display will blink slowly. Push one of the pushbuttons on the front panel to turn on the Be2K-Plus.

2.20 MANUAL mode

The MANUAL mode allows you to manually control the Engine and Contactors.

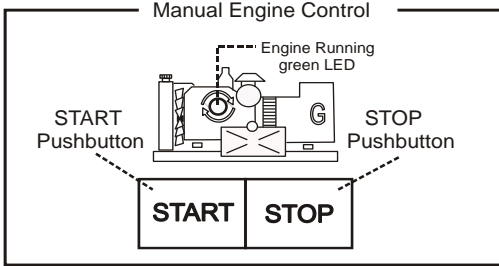
 <p>Manual Engine Control</p> <p>START Pushbutton</p> <p>STOP Pushbutton</p> <p>Engine Running green LED</p> <p>START STOP</p>	<p style="text-align: center;">Instructions</p> <p>Push the [MAN] pushbutton to select the MANUAL mode. Push the [START] pushbutton until engine starts; the display will automatically open the 'ENGINE STATUS PAGE' with information about the start sequence (see section 5.04). When the engine is running, the green LED, on the engine drawing, turns on. To stop the engine, push the [STOP] pushbutton until the [STOPPING] message appears on the display. If the engine has already stopped, it is possible to reset the STOP sequence by pressing the [STOP] pushbutton.</p>
---	--

2.21 Manual Control of the Contactors

To control the contactors follow the instructions:

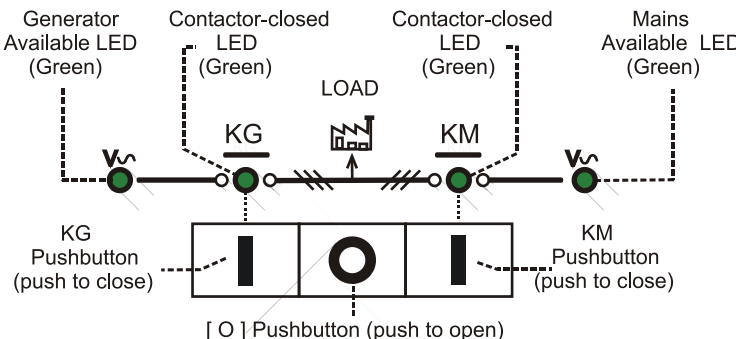
 <p>Generator Available LED (Green)</p> <p>Contactor-closed LED (Green)</p> <p>Contactor-closed LED (Green)</p> <p>Mains Available LED (Green)</p> <p>LOAD</p> <p>KG Pushbutton (push to close)</p> <p>[O] Pushbutton (push to open)</p> <p>KM Pushbutton (push to close)</p>	<p style="text-align: center;">Instructions</p> <p>Select the MANUAL mode, start the engine (see above) and wait until the green LED 'Generator Available' turns on. Push the [KG] pushbutton to close the contactor of the Generator. To transfer the Load to the Mains wait for the Green Light 'Mains available' and push the [KM] pushbutton: the KG will open and KM will close after a 2-seconds delay; the programmable changeover timer works only in AUTO mode.</p> <p style="text-align: center;"><u>To open a contactor, push the [O] pushbutton at anytime.</u></p>
--	---

!! WARNING !!

LINE VOLTAGE IS EXPOSED WITHIN THE Be2K-Plus AND ANCILLARY CIRCUITRY EVEN WHEN THE GREEN LEDs ARE TOTALLY OFF

2.30 AUTO mode

!! WARNING !!

The Be2K-Plus can start the engine at anytime. Do not work on equipment, which is controlled by the Be2K-Plus. When servicing the engine, disconnect the battery and battery charger. We recommend that warning signs be placed on equipment indicating the above.

Push the [AUTO] pushbutton until the green LED illuminates. The engine starts when the Be2K-Plus detects a Mains failure (section 12.01). The contactor of the Mains opens after the 'MAINS BREAKER' timing. After the 'WARM UP' time if the voltage and frequency are within the settings, the contactor of the Generator will close (section 12.02A). If the Mains restores, the KG will open. The KM will close following a programmed 'KM CHANGEOVER' timing. The engine will stop after a 'COOL DOWN' time. If the engine shuts down, the KM closes independently of the Mains status if the NFPA-110 is on (sections 12.06 & 18.30), otherwise the KM will close only if the parameters of the Mains are within the programmed settings. In AUTO mode, the Be2K-Plus will periodically test the engine if the periodic test is correctly programmed (section 7.01). During the test, the green LED of the AUTO mode will continue to blink. In AUTO mode, the Be2K-Plus can start and stop the engine if a remote control is activated (Table 12.10 options [25] or [26]). You can stop the engine at anytime by selecting the MAN mode. **(*)NOTE**





2.40 TEST mode

Push and hold the [AUTO] pushbutton until the green LED starts to blink. The Be2K-Plus will start the engine and transfer the load to the Generator only in case of Mains failure (if not otherwise programmed by the parameter 'KG TEST CONTROL' in section 7.02). To exit the TEST mode, push the [AUTO] pushbutton shortly or select an another mode of operation. **(*)NOTE**

(*)NOTE: If you push the [STOP] pushbutton when the Be2K-Plus is in AUTO or TEST, the 'FRONT PANEL EMERGENCY' alarm will energize (section 13.02A). To clear the alarm, select the OFF mode.

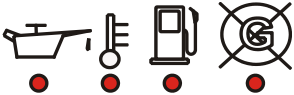
SECTION 3.00 - LEDS INDICATORS

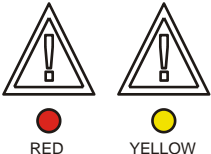
The table describes the LEDs functions on the front panel (section 1, figure 1). To test the LEDs, select the OFF mode, push and hold the [←F2] and [F3→] pushbuttons simultaneously. For NFPA 110, program an input with option [14] and connect an external pushbutton (see application note on section 18.30).

LED(s)	Note	LED(s)	Note
Indicators of Voltages and Contactor status (Vac, KM, KG....)	4 Leds (Green color). See section 2.21 for the description.	Manual Mode	
Engine Alarm Indicators 	4 Led indicators (red) for: -Oil pressure shutdown -Temperature shutdown -Tank Empty shutdown -Generator shutdown	 MAN	Green LED: it turns on indicating the MANUAL mode
	Red Led indicator: it turns on in case of a shutdown. Yellow Led indicator: it turns on in case of a warning. The display will indicate all details of the alarm(s).	Auto Mode 	Green LED: it turns on indicating the AUTO Mode. It will blink in TEST Mode.
		Engine Running (see Fig.1)	Green LED: it turns on when the engine is running.
		Current Mode & Voltage Mode (section1, Fig.1)	2 yellow LEDs indicate the mode of operation of the LED display (Voltage or Current). Push [ACK-F1] to toggle the display Mode.

Section 3.01 LED DISPLAY description

The red LEDs Display consists of 3 groups of 4 digits. The display on the **TOP** indicates Voltage or Current of Phase L1, the display on the **MIDDLE** the Phase L2 and the display on the **BOTTOM**, the Phase L3. Two yellow LEDs indicate the mode of the display (Voltage Mode and Current Mode). Push the [ACK-F1] button to toggle the display mode; the other yellow LED will illuminate. See figure 1 in section 1.00.

SECTION 4.00 GRAPHIC DISPLAY MAIN MENU

Push the [OFF] to select the OFF mode and push [F2 ←]; the following Main Menu will appear:

MAIN MENU LIST	Section	Use [↑] or [↓] to select a Menu and [→] to enter the Menu
MEASUREMENTS & EVENTS	5.00	Indicates all measurements and events
CLOCK SETTINGS	6.00	Allows you to set the Clock
TEST & RENTAL	7.00	Automatic Test, Rental and Telecom dedicated functions
MAINTENANCE TIMERS	8.00	Programming of scheduled service
READ PARAMETERS	12.00	You can read all parameters and setting
COMMUNICATIONS	10.00	Used to broadcast alarms and information
DISPLAY & LANGUAGE	11.00	Display settings and language selection
PROGRAM PARAMETERS	12.00	Allows you full access to the memory for programming
CLEAR MEMORY CLEAR EVENTS CLEAR ENERGY COUNTER CLEAR N° OF STARTS	9.00	Allows you to clear a particular area of the memory.
USER PASSWORD OEM PASSWORD	9.10	Allows you to set the OEM and USER password

After 30 seconds without operating the [↑][↓][←][→] pushbuttons, the display will shutdown.

SECTION 5.00 - MEASUREMENTS & EVENTS

Use [↑] or [↓] to select this Menu from the MAIN MENU LIST (section 4.0) and push [→].

Display Indication	Section	Instructions
GENERATING SET MAINS MONITORING POWER & ENERGY ENGINE & FUEL ALARMS STATUS EVENT HISTORY CALIBRATION	5.01 5.02 5.03 5.04 5.05 5.06 5.07-08	Use [↑] or [↓] to select a sub-menu and [→] to enter the submenu. Push [←] to return back.
ABOUT BE2K-PLUS		It provides miscellaneous information about the controller: - Software Version and Release - Engine Model and ECU Type (in case of J1939 use, see also the Be2k-J1939 User Manual)

Section 5.01 GENERATING SET

This Sub-menu indicates the following measurements:

Use [↑] or [↓] to select a page, use [←] to return			
L1-L2 (V) [XXXX]	CURRENT 1 [XXXX]	L1-N (V) [XXXX]	FREQUENCY [XX.X] SEQUENCE [CW/CCW]
L2-L3 (V) [XXXX]	CURRENT 2 [XXXX]	L2-N (V) [XXXX]	CONTACTOR [ON/OFF] EARTH FAULT [X.XX]
L1-L3 (V) [XXXX]	CURRENT 3 [XXXX]	L3-N (V) [XXXX]	SIMULATED (+) [ON/OFF]

(+) see option [11] in the table 12.10. It indicates that the Generator presence is simulated

Section 5.02 MAINS MONITORING

This Sub-menu indicates the following measurements:

Use [↑] or [↓] to select a page, use [←] to return		
R - S (V) [XXXX]	R - N (V) [XXXX]	FREQUENCY [XX.X] SEQUENCE [CW/CCW]
S - T (V) [XXXX]	S - N (V) [XXXX]	CONTACTOR [ON/OFF] SIMULATED (++) [ON/OFF]
T - R (V) [XXXX]	T - N (V) [XXXX]	TELECOM VDC (+++) [XX.X]

(++) see option [12] in the table 12.10. It indicates that the Mains presence is simulated
(+++) it indicates the voltage of the Telecom battery pack (in a range 8-60Vdc)

Section 5.03 POWER & ENERGY

This Sub-menu indicates the following measurements:

Use [↑] or [↓] to select a page, use [←] to return		
KVA 1 [XXXX]	KVAR 1 [XXXX]	KW 1 [XXXX]
KVA 2 [XXXX]	KVAR 2 [XXXX]	KW 2 [XXXX]
KVA 3 [XXXX]	KVAR 3 [XXXX]	KW 3 [XXXX]
PF 1 [X.XX]	TOTAL KW [XXXX]	PF TOTAL [X.XX]
PF 2 [X.XX]	TOTAL KVA [XXXX]	ENERGY KWH [XXXXXXXXXX]
PF 3 [X.XX]	TOTAL KVA _r [XXXX]	

Section 5.04 ENGINE & FUEL

This Sub-menu contains information about the status of the engine.

ENGINE STATUS PAGE																																					
push the [↓] to browse all the other pages related to the engine																																					
ENGINE STATUS [MESSAGE 1] [MESSAGE 2] COUNTING [XXXX] DATE [XX.XX] TIME [XX:XX] HOUR RUN [XXXXXXXXXX]	This page can indicate two messages that describe the status of the engine and the status of the active timer (COUNTING). Possible messages are: <table border="1" style="width: 100%; text-align: center;"> <tr> <td colspan="2">RUNNING</td> <td colspan="2">NOT RUNNING</td> <td colspan="2">RUNNING ON LOAD</td> </tr> <tr> <td>REST</td> <td>PRELUBE</td> <td>STARTING</td> <td colspan="3">CRANKING</td> </tr> <tr> <td colspan="2">STOPPING</td> <td colspan="2">COOLING</td> <td colspan="2">WARM UP</td> </tr> <tr> <td colspan="2">IDLE SPEED</td> <td colspan="2">PREGLOW</td> <td colspan="2">PERIODIC TEST</td> </tr> <tr> <td colspan="2">MAINS BREAKER DELAY</td> <td colspan="2">MAINS FAILURE DELAY</td> <td colspan="2">REMOTE TEST</td> </tr> <tr> <td colspan="3">MAINS RESTORE DELAY</td> <td colspan="3">TELECOM INHIBIT</td> </tr> </table> <p style="text-align: center;">The engine run hours and Date / Time are also indicated</p>	RUNNING		NOT RUNNING		RUNNING ON LOAD		REST	PRELUBE	STARTING	CRANKING			STOPPING		COOLING		WARM UP		IDLE SPEED		PREGLOW		PERIODIC TEST		MAINS BREAKER DELAY		MAINS FAILURE DELAY		REMOTE TEST		MAINS RESTORE DELAY			TELECOM INHIBIT		
RUNNING		NOT RUNNING		RUNNING ON LOAD																																	
REST	PRELUBE	STARTING	CRANKING																																		
STOPPING		COOLING		WARM UP																																	
IDLE SPEED		PREGLOW		PERIODIC TEST																																	
MAINS BREAKER DELAY		MAINS FAILURE DELAY		REMOTE TEST																																	
MAINS RESTORE DELAY			TELECOM INHIBIT																																		

Use [↑] or [↓] to select a page, use [←] to return			
SPEED [XXXX]	FUEL LEVEL [XX]	RENTAL H (!) [XXXX]	
OIL PRESSURE [XX.X]	TRANSFER PUMP [ON-OFF]	MAINTEN. 1 (!) [XXXX]	
COOLANT °C [XXX]	V BATTERY [XX.X]	MAINTEN. 2 (!) [XXXX]	
	ALTERNATOR V [XX.X]	MAINTEN. 3 (!) [XXXX]	
	N° / STARTS [XXXXXXXX]		

(!) It indicates the remaining hours before expiring the Maintenance timers and Rental contract (see sections 7.01 & 8.0). If the engine is connected by means of SAE-J1939 (Can Bus), additional pages are available:

Use [↑] or [↓] to select a page, use [←] to return			
OIL °C [XXX]	OIL °C [XXX] SPN 175	WATER IN FUEL [ON/OFF] SPN 97	FUEL RATE [XXX] SPN 183
AUXILIARY °C [XXX]	OIL LEVEL [XX.X] SPN 98	FUEL °C [XXX] SPN 174	PEDAL % [XXXX] SPN 91
	OIL PRESSURE [XX.X] SPN 100	FUEL BAR [XXX] SPN 94	TURBO BAR [XX.X] SPN 102

Use [↑] or [↓] to select a page, use [←] to return			
EXHAUST [XXXX] SPN 173	COOLANT °C [XXX] SPN 110	CRANKCASE BAR [XXXX] SPN 101	DEMANDE TORQUE [XXXX] SPN 512
BAROMETRIC P. [XXXX] SPN 108	COOLANT % [XX.X] SPN 111	BOOST °C [XXXX] SPN 105	ACTUAL TORQUE [XXXX] SPN 513
	COOLANT BAR [XXXX] SPN 109	INTAKE BAR [XXXX] SPN 106	LOAD [XXXX] SPN 92

NOTE: Additional information from J1939 will be displayed using the coding of the engine manufacturer (see the engine's OEM manual).

Section 5.05 ALARM STATUS

This Sub-menu can contain 10 pages of active alarms together with real time clock indication and alarm information. A typical alarm page is indicated below (see section 13.0 for the list of all alarms):

Instructions	
ALARMS PAGE 1 OF 10 OIL PRESSURE WARNING VALUE: 0,8 BAR DD:MM:YY HH:MM:SS	Use [↑] or [↓] to browse the content of the pages This page opens automatically in case of alarm(s). The alarm status is also recorded in the Memory Events register. To return to the MEASUREMENTS pages, push the [←] pushbutton.

In case of alarms detected via CAN-BUS (J1939), the Be2K-Plus will decode the CAN BUS information. Consult the user manual of the engine manufacturer for further details.

ALARMS PAGE	1 OF 10
[DESCRIPTION OF ALARM]	
SPNXXX	FMI XX
DD:MM:YY	HH:MM:SS

This page opens automatically in case of alarm(s). The alarm status is also recorded in the Memory Events register (see 5.06). To return to the MEASUREMENTS pages, push the [←] pushbutton.
--

Section 5.06 EVENT HISTORY

This submenu displays 70 pages providing Date & Time information for about 200 Events of: Warnings, Shutdowns, switching of the Contactors and changing of Operating Modes.

Instructions	
EVENT HISTORY 1 / 70 EMERGENCY DD:MM:YY HH:MM:SS	Push [↑] or [↓] to browse the list of the events. To return to MEASUREMENTS, push the [←] pushbutton. (see section 13.0 for the description of the alarms)

Note: in order to cancel the EVENT HISTORY, use the CLEAR EVENTS menu described in section 9.0.

Section 5.07 Calibration

Use [↑] or [↓] to select this Menu from the MEASUREMENTS & EVENTS Menu. Push [MAN] to select the Manual mode and push [→] to enter the menu.

If the function is Password protected, type the password (see section 9.10). If password is valid, the list indicated in TABLE 5.08 will appear.

To calibrate, follow the instructions:

- (A) - Start the engine (if necessary) and wait for the generator to stabilize.
- (B) - Select a parameter by using the [↑] or [↓] button.
- (C) - Push the [→] button to enter the numerical field of the parameter.
- (D) - Be sure that the reference measurement is stable and within the recommended range (Table 5.08).
- (E) - Modify the indication of the display, using [↑] or [↓], until the display matches the reference.
- (F) - Exit the numerical field using the [←] pushbutton.
- (G) - Select an other function to calibrate or exit using the [←] pushbuttons; you have 3 options:

Push F1 to Save and Exit / < Push F2 to Exit / > Push F3 to Return back

- (H) - Stop the engine, remove the Vdc supply for a minute; connect the Vdc supply.
- (I) - Start the engine and verify the measurement that you calibrated. If necessary repeat the entire procedure.

Note: in case of doubt, it is possible to restore the factory calibration by using the [RESTORE] function. After that the Be2K-Plus will ask to choose one of the options : Save, Exit or Return back.

Table 5.08 Calibration table

Display indication Description & numerical Field		Unit	Range	Display indication Description & numerical Field		Unit	Range
VOLTAGE L1-N	XXX	Volt	200 - 250	AUX. TEMP °C	XXX	Degree Celsius	90 -100
VOLTAGE L2-N	XXX			OIL TEMPERATURE	XXX		
VOLTAGE L3-N	XXX			COOLANT °C	XXX		
VOLTAGE R-N	XXX			OIL PRESSURE	XX.X	Bar	2 - 6
VOLTAGE S-N	XXX			FUEL LEVEL	XX	%	70 - 80
VOLTAGE T-N	XXX			BATTERY	XX.X	Volt	12 -26
CURRENT L1	XXX	Ampere	3 – 5	FREQUENCY	XX.X	Hertz	48 - 65
CURRENT L2	XXX			SPEED	XXXX	RPM	1300 up to 1500
CURRENT L3	XXX						
RESTORE		This function allows you to restore the factory calibration. Push [→] to enter the function and follow the instruction that will appear on the display.					

SECTION 6.00 - CLOCK SETTINGS

Use [↑] or [↓] to select this Menu from the MAIN MENU list (section 4.0) and push [→] to enter the menu. Setting of Clock is allowed in OFF mode only.

Display Indication	Instructions
CLOCK DAY 1	Use [↑] or [↓] to select a function. Push [→] to enter the numerical field.
CLOCK MONTH 1	Push [↑] or [↓] to set a value. Push [←] to return to the function.
CLOCK YEAR 2000	After setting the clock, push [↓] to select the [PUSH F3 TO SET CLOCK] function (see below) in order to start the clock.
CLOCK HOUR 0	
CLOCK MINUTE 0	
DATE FORMAT DD:MM:YY	Select the function, push [→] and [↑] or [↓] to select the option MM:DD:YY (Month:Day: Year) instead of DD:MM:YY (Day:Month:Year).
PUSH F3 TO SET CLOCK	Push [F3 →] to start up the Be2k-Plus at the proper moment (use an external clock reference)

SECTION 7.00 - TEST & RENTAL PROGRAM ('USER password' is required for programming)

7.01: Periodic Test Settings

Use [↑] or [↓] to select this Menu from the MAIN MENU list (section 4.0) and push [→] to enter the menu.

Display Indication	Description
TEST DAY 1	Periodic Test setting. You can set the date of the Periodic Test. The engine will run for the [TEST DURATION] time. The Be2k-Plus will repeat the test every [TEST REPEAT] days. After a test, the DATE is automatically updated to inform you about the date of the next TEST attempt. In order to program correctly, make sure not to set the scheduled date at a time that has already occurred. Instructions: Use [↑] or [↓] to select a function. Push [→] to enter the numerical field. Push [↑] or [↓] to set a value. Push [←] to return to the function. After setting date and time, push [↓] to select the TEST DURATION. Automatic Test works in AUTO mode. The green LED blinks during the Test, and output with option [55] turns on)
TEST MONTH 1	
TEST YEAR 2008	
TEST HOUR 0	
TEST MINUTE 1	
TEST DURATION OFF	Duration of the test (1-60 minutes, or OFF to disable the TEST).
TEST REPEAT OFF	Repetition rate of the test (1-60 days, or OFF to disable the TEST). Push [←] to return to the function. The Be2k-Plus will start to count-up the time.

7.02: Rental, EJP (France), Test Mode & Dual Set mode

Display Indication	Description
RENTAL CONTRACT OFF	You can set up to 9999 hours of rent contract. When the remaining hours drop to less than 48, the 'RENTAL WARNING' alarm sets off. At 'ZERO' hours, the engine will shutdown. You are required to re-program the timer.
EJP 5" (Effacement des Jours de Pointe).	(Range 1sec - 99 minutes). This timer delays the switching of the contactor of the Generator (KG) if the engine has been started using the EJP (see table 12.10, option [13]).
KG TEST CONTROL OFF	Options: [ON or OFF]. The option ON will transfer the Load to the Generator if you select the TEST mode from the front panel. The option OFF will allow you to run the engine without switching the Load. Mains Failure overrides the option [OFF].
RUN TIMEOUT OFF	Maximum time allowed for running the engine (up to 24 hours). The option OFF disables the time-out and the engine will run until a stop is required. The counter works in Manual mode also, but it will not shut down the engine. Before selecting AUTO mode, push the OFF button.
2XGEN. + MAINS OFF	1minute up to 24h. See application note described in section 18.20

7.03: Battery monitoring, Telecom Battery monitoring, Room temperature monitoring

Display Indication	Description
LOW BATT. START OFF	(8-30V).The engine will start when the Battery Voltage (of the engine) falls under the LOW setting. The engine will stop when the voltage rises above the HIGH setting. A delay of 2 minutes prevents a false trigger of the function. Battery voltage is detected on supply input J11-2-3.
HIGH BATT. STOP OFF	
H AUX °C START OFF	(Range 0-60°C).The engine will start when the Auxiliary temperature rises above the HIGH setting. The engine will stop when the Auxiliary temperature falls below the LOW setting. A delay of 2 minutes prevents false trigger of the function (see 12.03C for setting the input).
L AUX °C STOP OFF	
TELECOM BATT. OFF	Telecom Battery & Room monitoring. You can set the HIGH limit of the Room temperature (use Auxiliary temperature input, see 12.03C) and the LOW limit of the Telecom Battery Pack (8-60Vdc, input JM6) in order to inhibit the start of the Generator in case of Mains failure. Program an output with the option Telecom Room Monitoring ([71]) connected to an input programmed with Mains Simulated option ([12]). In case of Mains Failure, the engine will not start if the temperature is low and the Battery Voltage is above the setting. You can disable one function (BATTERY or TEMPERATURE) by choosing the option OFF.
TELECOM °C OFF	
TELECOM V LOW OFF	These parameters allow you to set a warning if the Battery voltage of the TELECOM equipment is low or high. A bypass delay of 2 minutes cancels a false trigger of the warning. The analog input dedicated to this function is the terminal JM6 (8-60Vdc).
TELECOM V HIGH OFF	
TELECOM °C LOW OFF	These parameters allow you to set a warning if ambient temperature is low or high . A bypass delay of 2 minutes is added. You can program the analog input in the AUX TEMPERATURE PAGE (section 12.03C) and an output with the option [79] (Table 12.11).
TELECOM °C HIGH OFF	

SECTION 8.0 - MAINTENANCE TIMERS

Use [↑] or [↓] to select this Menu from the MAIN MENU list (section 4.00) and push [→] to enter the menu. These functions are 'User password' protected.

Display Indication	Section	Instructions
MAINTENANCE 1 OFF		Use [↑] or [↓] to select a function. Push [→] to select the numerical field. Push [↑] or [↓] to set a value. Push [←] to return to the function. The timers 1, 2 and 3 set the hours of Maintenance time out. Maintenance 1 and 2 will generate a warning alarm. Maintenance 3 will shutdown the engine. The remaining time is indicated in the ENGINE page (see 5.04). When a timer expires, enter this screen and exit (push [←]). The timer will restart automatically. Restarting of timer(s) is not allowed by remote (e.g. by computer or Modbus).
MAINTENANCE 2 OFF		
MAINTENANCE 3 OFF		

SECTION 9.00 - MEMORY & PASSWORD

Enter the OFF mode, select the function you require from the Main Menu list (see section 4.0). Push [→] to enter the function.

Display Indication	Instructions
<p>CLEAR MEMORY (Total cancellation of the memory and restoration of factory settings)</p> <p>CLEAR EVENTS (It cancels the Event History, see section 5.06)</p> <p>CLEAR ENERGY COUNTER (It cancels the counter of the Energy, see 5.03)</p> <p>CLEAR N° OF STARTS (It cancels the number of starts, see 5.04)</p>	<p>To enter the functions listed on the left, you have to provide a correct password as indicated in section 9.10.</p> <p><u>Note: some functions indicated on the left, will require a confirmation as indicated below</u></p> <p>Push the [↓] button to select 'PUSH F3 TO CONFIRM' and [F3 →] to trigger the operation (figure 9.1). The message [DONE] will appear (figure 9.2).</p> <div style="display: flex; justify-content: space-around; align-items: center;"> <div style="border: 1px solid black; padding: 5px; text-align: center;"> <p>Figure 9.1</p> <p>PUSH F3 TO EXIT PUSH F3 TO CONFIRM</p> </div> <div style="border: 1px solid black; padding: 5px; text-align: center;"> <p>Figure 9.2</p> <p>DONE</p> </div> </div>

9.10: Password programming

9.11 User or OEM password selection:

Enter the OFF mode, select the function you require from the Main Menu list (see section 4.0). Push [→] to enter the function.

Display Indication	Instructions
USER PASSWORD OEM PASSWORD	Use [↑] or [↓] to select a function and push [→] to enter the function; the following screen will appear (section 9.12 describes an example)

9.12 User or Oem passwords programming (example for 'User'):

Display Indication	Instructions
ENTER USER PASSWORD	A) - Use [←] or [→] to select a digit of the password.
CANCEL - - - - OK	B) - Push [↑] or [↓] to edit the digit (Number or Upper case letter).
SELECT OK TO CONFIRM	C) - Repeat steps A) and B) in order to edit the 4-digit password. D) - Select OK using the [→] button (the OK highlights when selected). E) - Push the [→] button to confirm the password.

9.13 User or Oem passwords options:

Display Indication	Instructions
CHANGE USER PASSWORD	Once you've entered the correct password, the Be2k-Plus presents the options to change or to clear the User / OEM password. A) - Push [↑] or [↓] to select the function B) - Push [→] to enter the function C) - Follow menu-driven instructions to complete the task
CLEAR USER PASSWORD	
CHANGE OEM PASSWORD	
CLEAR OEM PASSWORD	

SECTION 10.0 - COMMUNUCATIONS & SERIAL INTERFACES

Use [↑] or [↓] to select this Menu from the MAIN MENU list (section 4.0) and push [→] to enter the menu. Additional information is described in the BE-2KPLUS communication User Manual.

NOTE: By means of software, provided by us, you are allowed to write into Be2K-Plus the Serial Number and Name of the Location or Plant.

Display Indication	Section	Instructions
RS485 NODE 1	10.01	Use [↑] or [↓] to select a function. Push [→] to select the numerical field. Push [↑] or [↓] to set a value. Push [←] to return back.
MODEM SETTINGS	10.02	
TCP/IP SETTTINGS	10.03	

Section 10.01: RS485 node

Push [→] to select the numerical field. Push [↑] or [↓] to set a value. Push [←] to return back. The range of the Node address is in between 1 to 127. In order to establish a communication with Be2k-Plus, the Node Address must match the calling device node address.

Section 10.02: Modem settings

The details of these functions are described in the BE-2KPLUS communication User Manual

Section 10.03: TCP-IP settings

The details of these functions are described in the BE-2KPLUS communication User Manual

SECTION 11.0 - DISPLAY & LANGUAGE

Use [↑] or [↓] to select this Menu from the MAIN MENU list (section 4.00) and push [→] to enter the menu.

Display	Instructions
LANGUAGE	A) - Use [F3 →] button to enter the selection of the language. Choose the language using [↑] or [↓]. B) - Push the [F2 ←] twice; the display will indicate the 3 options: - EXIT by pushing [F2 ←] - SAVE (the selection of the language) by pushing [F1] - RETURN BACK (to selection language) by pushing [F3 →] Languages available are ENGLISH-ITALIAN-FRENCH-GREEK-SPANISH-RUSSIAN
CONTRAST 75%	You can optimize the text-readability of the display: - Push [F3 →] button to enter; push [↑] or [↓] to choose 25%, 50% ,75% or 100% - Push [←] to return BACK

SECTION 12.00 - PROGRAMMING PARAMETERS

We recommend that you use the software Be2K-Plus SCADA for programming the controller (see the Be2K-Plus SCADA software guide). Be2K-Plus however, allows programming using the push buttons on the front panel. Follow the instructions:

(1) – Preliminary operation:

Push OFF pushbutton to enter the OFF mode. Select the PROGRAM PARAMETERS Menu from the Main Menu list (section 4.00)

(2) – Password:

If a password was inserted, the Be2k-Plus will present a screen to enter the password (see below)

Display Indication	Note
ENTER USER PASSWORD	A) - Use [←] or [→] to select a digit of the password.
CANCEL - - - - OK	B) - Push [↑] or [↓] to edit the digit (Number or Upper case letter). C) - Repeat steps A) and B) in order to edit the 4-digit password.
SELECT OK TO CONFIRM	D) - Select OK using the [→] button (the OK highlights when selected). E) - Push the [→] button to confirm the password.
	If the password is correct, the message [PASSWORD OK] will be displayed

(3) – Parameters Menu:

If entered a proper password, the Be2k-Plus presents the menu of the programmable parameters:

PARAMETER MENU	See Section:	PARAMETER MENU	See Section:
MAINS PARAMETERS	12.01	OIL PRESSURE INPUT	12.07 (Table)
GENERATOR PARAMETERS	12.02 A-B	COOLANT °C INPUT	12.08 (Table)
ENGINE PARAMETERS	12.03 A-B-C	FUEL LEVEL INPUT	12.09 (Table)
SPEED PARAMETERS	12.04	CONFIGURABLE INPUTS	12.10
FUEL SETTINGS	12.05	CONFIGURABLE OUTPUTS	12.11
MISCELLANEOUS	12.06	CAN BUS SETTINGS	12.12
AUXILIARY °C INPUT	12.08 (Table)	RESTORE DEFAULTS	12.13
OIL °C INPUT	12.08 (Table)		

(4) – Select the programmable parameters:

Choose the MENU that requires programming by using the [↑] or [↓] buttons and push [→]. The list of the parameters will appear on the display

(5) – Programming:

- 5 A** - Select a parameter by using the [↑] or [↓] buttons (see sections 12.01-----12.13)
- 5 B** - Push the [→] button to enter the numerical field of the parameter
- 5 C** - Modify the parameter using [↑] or [↓]
- 5 D** - Exit the numerical field using the [←] pushbutton.
- 5 E** - You can modify an other parameter by repeating the steps 5A-B-C-D
- 5 F** - Use the [←] pushbutton to return. The Be2K-Plus will provide you 3 options:

Push F1 to Save / < Push F2 to Exit / > Push F3 to Return back

5 G - Choose the proper option; disconnect the supply, re-apply the supply and verify that the modifications have been saved in a way that Be2K-Plus operates according to your need.

Reading Parameters Instructions

To read the parameters without entering the programming, follow the instructions:

(1) – Push the [OFF] button to enter the OFF mode; push [←F2]

(2) – Select from the MAIN MENU LIST (see section 4.0), the function [READ PARAMETERS]; push [F3 →]
The PARAMETERS MENU will appear on the screen of the display (see below).

(3) – Choose one Menu from the **PARAMETERS MENU** list by using the [↑] or [↓] buttons and push [F3 →] to enter the Menu. Push [F4 ↑] or [F5 ↓] to browse the parameters. Push [←F2] to return.

Section 12.01 **MAINS PARAMETERS** submenu

note: (") stands for seconds, (') stands for minutes

Display Indication	Min	Max	Options	Note
MAINS BREAKER 5"	0	59'	-	In case of Mains failure, the [MAINS BREAKER] timer will delay the opening of the contactor.
MAINS FAILURE 5" MAINS RESTORE 5"	0 0	23h,59" 23h,59"	- -	These two timers will delay the start and stop of the engine in order to cancel false Mains Failure/Restore conditions.
KM CHANGEOVER 2.0	0.1"	15.0"	-	Dead time between the switching of the contactors.
UNDER VOLTAGE 320 OVER VOLTAGE 500	60 60	9990 9990	OFF OFF	Define operating limits for the Mains. If a parameter is out of limits, a Mains failure condition will occur.
UNDER HZ 47.0 OVER HZ 53.0	20.0 20.0	70.0 70.0	OFF OFF	
PHASE MODE 3 PH	1PHASE, 3PH, 3PH+CW or 3 CCW			
PHASE UNBALANCE OFF	10	999	OFF	If the difference between phases rises above the setting, a Mains failure condition will take place. The option [OFF] disables the monitoring.
VAC RATIO 1.0	1.0	15.0	-	It allows the use of voltage transformer extending the reading up to 9990Vac.

Section 12.02A **GENERATOR CONTROL** submenu

note: (") stands for seconds, (') stands for minutes

Display Indication	Min	Max	Options	Note
UNDER VOLTAGE 320 BYPASS DELAY 6"	60 1"	9990 15"	OFF -	Define operating limits for the Generator. If a parameter is out of the limits, the Be2k-Plus triggers the alarm and stops the engine.
OVER VOLTAGE 500 BYPASS DELAY 6"	60 1"	9990 15"	OFF -	
UNDER HZ 47.0 BYPASS DELAY 6"	20.0 1"	70.0 15"	OFF -	
OVER HZ 53.0 BYPASS DELAY 6"	20.0 1"	70.0 15"	OFF -	Under V & Under Hz works only if the contactor of the Generator is closed.
WARNING CURRENT OFF BYPASS DELAY 6"	1 1"	9990 15'	OFF -	The option ON in the [ALTERNATOR FAIL] parameter, will shutdown the engine if the parameters of the Generator are outside of the operating range for at least 300 seconds from engine start.
OVER CURRENT OFF BYPASS DELAY 6"	1 1"	9990 15'	OFF -	
SHORT CIRCUIT OFF BYPASS DELAY 0,5"	1 0.0"	9990 15.0"	OFF -	
ALTERNATOR FAIL OFF	ON or OFF			
PHASE MODE 3 PH (Section 18.10 for single Ph mode)	1PHASE, 3PH, 3PH+CW or 3 CCW		1= single Phase, 3=3 Phases without sequence control. The option CW/CCW controls the requested sequence of Phases. In case of reverse sequence, the engine will shutdown ('PHASE SEQUENCE ERROR', section 13.04).	

Section 12.02B **GENERATOR CONTROL** submenu note: (") stands for seconds, (') stands for minutes

Display Indication	Min	Max	Options	Note
MAX KW LIMIT OFF BYPASS DELAY 30"	10 1"	9990 59'	OFF -	To monitor the KW, you can program two outputs with option [10] and [11] (see Table 12.10). The outputs energize if KW is outside limits and reset if KW is within limits. A bypass delay should be programmed according to the characteristics of the LOAD.
MIN KW LIMIT OFF BYPASS DELAY 30"	10 1"	9990 59'	OFF -	
KVA SHUT DOWN OFF BYPASS DELAY 30"	10 1"	9990 59'	OFF -	If the power rises above the [KVA SHUT DOWN] limit for at least the [BYPASS DELAY] time, the Be2K-Plus opens the contactor and shuts down the engine, The [OFF] setting (>9990KVA) disables the alarm.
REVERSE POWER OFF BYPASS DELAY 1"	10 1"	9990 15"	OFF -	If kW1 (or 2, 3) becomes negative and exceeds the limit, the KG opens and the engine will shutdown after a cooling down time.
EARTH FAULT OFF BYPASS DELAY 1.0"	0.1 0.3"	99.9 10"	OFF -	Provides Earth Fault current (or Differential Protection) Monitoring.
CT SIZE EARTH 5	5	9990	-	It defines the size of the CT for the Earth Current
VAC RATIO 1.0	1.0	15.0	-	It extends the reading range of the Vac up to 9990Vac
PHASE UNBALANCE OFF BYPASS DELAY 15"	10 1	999 59"	OFF	If the difference of voltage between phases rises above the setting, the KG opens and the engine will shutdown after a cooling down time. The option [OFF] disables the Unbalance monitoring.
CT SIZE L1 L2 L3 500	5	9990	-	It defines the sizes of the CT for the phases L1-2-3 of the Generator.

Section 12.03 A **ENGINE PARAMETERS** submenu note: (") stands for seconds, (') stands for minutes

Display Indication	Min	Max	Options	Note
PRE-LUBE TIME 2"	1"	15"		It energizes the Pre-lube pump (option [63], section 12.11) or it delays the crank if necessary (option [46]).
CRANK TIME 5" CRANK REST TIME 5" START ATTEMPTS 3	1" 3" 3	15" 15" 15		These parameters define the start sequence of the engine.
PREGLOW TIME OFF PREGLOW MODE 1	1" -	15' -	OFF 1-2-3-4	See Figure 12.03A in order to choose the proper working logic of Output JC1.
CRANK TERMINATION	CRANK TERMINATION programming These parameters allow you to terminate the crank when the engine starts to run.			
CHARGER VOLTAGE 8.0	3.0	30.0	OFF	Charger alternator voltage (input #JC10)
GENERATOR VAC 60	60	9990	OFF	Generator Voltage Line to Neutral (inputs #JA5-6-7-8)
GENERATOR HZ 25.0	20.0	70.0	OFF	Generator Frequency (inputs #JA5-6-7-8)
SPEED RPM 300	100	800	OFF	Pick-up or 'W' (you are required to program the TOOTH COUNT as indicated in section 12.04.
CANBUS OFF	1	60	OFF	CAN BUS. You can set the number of times that Be2k-Plus detects a true engine running condition.
GAS PURGE 1"	1"	15"	OFF	It allows you to use a GAS fuelled engine; (Program an output with option [47], see table 12.11).
WARM UP 15"	0	59'	-	The Generator Contactor will close after [WARM UP].

COOL DOWN TIMER 15"	0	59'	-	The will run engine run Off-Load.
STOP SOLENOID 15"	1"	15'	-	Energized to stop solenoid timing (Output #JC4)
BELT BREAK VDC 8.0	3.0	30.0	OFF	Setting to detect Charger Alternator Failure
ALARM BYPASS 10"	2"	99"	-	Bypass timing for Oil, Temperature and Alarm 1 alarms.
FAIL TO STOP OFF	ON or OFF			You can disable the FAIL to Stop alarm.

Figure 12.03A: Preglow-modes timing diagram

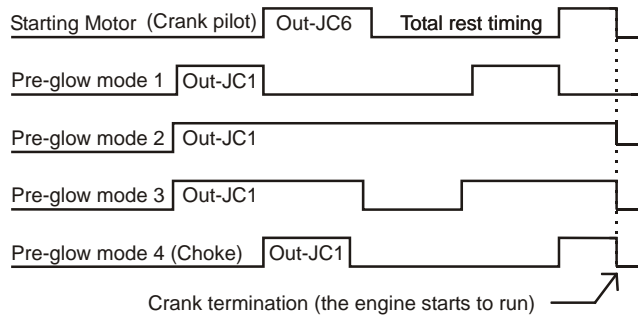

Section 12.03B **ENGINE PARAMETERS** submenu note: (") stands for seconds, (') stands for minutes

Display Indication	Min	Max	Options	Note
OIL PRESSURE PAGE				
LOW BAR WARNING OFF	0.1	20.0	OFF	It allows you to monitor the Oil Pressure (BAR). You can set a Low Oil Pressure warning or a Low Oil Pressure shutdown. The alarm is ignored during By-pass timing.
LOW BAR SHUT. OFF	0.1	20.0	OFF	
ANALOG INPUT OFF	[1] to [5] select the analog input. The setting [OFF] disables the input; the display will indicate dashes instead of a BAR.			
ANALOG MODE (*) [OHM]	[OHM] for sensor input [3] to [5]. [4-20MA]/[0-10V]/[0-5V] for inputs [1] & [2]. The [J1939] detects Oil Pressure form CAN-BUS.			
OIL TEMPERATURE PAGE				
HIGH °C WARNING OFF	1	250	OFF	It allows you to monitor the Oil Temperature. The alarm is ignored during By-pass timing.
HIGH °C SHUTDOWN OFF	1	250	OFF	
ANALOG INPUT OFF	[1] to [5] select the analog input JM1 - - 5. The setting [OFF] disables the input; the display will indicate dashes instead of °C degree.			
ANALOG MODE (*) [OHM]	[OHM] for sender input [3] to [5]. [4-20MA]/[0-10V]/[0-5V] for inputs [1] & [2]. The [J1939] detects Oil Temperature form CAN-BUS.			

(*) The functions mA/Bar, V/Bar, mA/°C or V/°C are indicated in tables 12.07-08-09.

Section 12.03C **ENGINE PARAMETERS** submenu note: (") stands for seconds, (') stands for minutes

Display Indication	Min	Max	Options	Note
COOLANT PAGE				
HIGH °C WARNING OFF	1	250	OFF	It allows you to monitor the Coolant Temperature. You can set a Low / High limit. The alarms are ignored during By-pass timing.
LOW °C WARNING OFF	1	250	OFF	
HIGH SHUTDOWN OFF	1	250	OFF	
ANALOG INPUT OFF	[1] to [5] select the analog input JM1 - - 5. The setting [OFF] disables the input; the display will indicate dashes instead of °C degree.			
ANALOG MODE (*) [OHM]	[OHM] for sensor input [3] to [5]. [4-20MA]/[0-10V]/[0-5V] for inputs [1] & [2]. [J1939] detects Coolant Temperature form CAN-BUS.			
AUX TEMPERATURE PAGE				
HIGH WARNING OFF	1	250	OFF	It allows you to monitor an auxiliary Temperature (Canopy or Room temperature for example). You can set warnings or shutdowns. Refer to section 7.03 for Room Temperature monitoring and alarm settings.
HIGH SHUTDOWN OFF	1	250	OFF	
ANALOG INPUT OFF	[1] to [5] select the analog input JM1- - 5. The setting [OFF] disables the input; the display will indicate dashes instead °C degree.			
ANALOG MODE (*) [OHM]	[OHM] for sender input [3] to [5]. [4-20MA]/[0-10V]/[0-5V] for inputs [1] & [2]. The [J1939] option is a non valid selection.			

() The functions mA/Bar, V/Bar, mA/°C or V/°C are indicated in tables 12.07-08-09 .*

Section 12.04 **SPEED PARAMETERS** submenu note: (") stands for seconds, (') stands for minutes

Display Indication	Min	Max	Options	Note
TOOTH COUNT OFF	10.0	500.0	OFF	The tooth count is programmed in steps of 0.1 allowing you to obtain a correct speed indication in case of use of Charging Alternator ('W'). The overspeed setting is automatically increased 5 %, during ALARM BYPASS (section 12.0A)
UNDER SPEED OFF	100	4000	OFF	
BYPASS DELAY 6"	1"	15"	-	
OVERSPEED OFF	100	4000	OFF	
BYPASS DELAY 1"	1"	15"	-	
IDLE TIME OFF	1"	59'	OFF	Program the option [60] on one digital output. The output will remain activated for [IDLE TIME] after engine start. You can preset the speed externally.
IDLE SPEED OFF	100	4000	RPM	Used only in case the Be2k-Plus interfaces with an ECU
NOMINAL SPEED OFF	100	4000	RPM	
DROOP SETTING OFF	0.1	10.0	%	
NUMBER OF POLES 4	2	4	OFF	It calculates the speed using the frequency of the Generator voltage.

Section 12.05 **FUEL SETTINGS** submenu

note: (") stands for seconds, (') stands for minutes

Display Indication	Min	Max	Options	Note
TANK EMPTY OFF	1%	99%	OFF	Be2k-Plus shuts down the engine if the level drops below the limit for the [TANK EMPTY DELAY] time (see below).
TANK EMPTY DELAY 5'	15"	59'	OFF	Be2k-Plus shutdowns the engine if a low fuel condition (level switch or analog input) persists for more than [TANK EMPTY DELAY]. Option [OFF] provides an immediate Shutdown.
LOW FUEL WRN OFF HIGH FUEL WRN OFF	1% 1%	99% 99%	OFF OFF	It monitors the Fuel Sensor providing an alarm warning (Bypass=15 seconds).
ANALOG INPUT OFF	[1] to [5] select the analog input JM1- - 5. The setting [OFF] disables the input; the display will indicate dashes instead of a level %.			
ANALOG MODE (*) [OHM]	[OHM] for sensor and [4-20MA]/[0-10V]/[0-5V] for transmitter (*). The [J1939] option, detects Fuel Level from the CAN-BUS			
PUMP START OFF PUMP STOP OFF PUMP TIMEOUT OFF	1% 1% 15"	99% 99% 59'	OFF OFF -	Program option [32] for driving a pump to fill the tank. A delay of 15 seconds for start and stop is provided. The PUMP TIMEOUT alarm disables the output and triggers the alarm. The pump is disabled in OFF mode. <u>We recommend that you provide an external On-Off-Auto switch to control the pump manually.</u>

(*) The functions mA/Bar, V/Bar, mA/°C or V/°C are indicated in tables 12.07-08-09 .

Section 12.06 **MISCELLANEOUS** submenu

note: (") stands for seconds, (') stands for minutes

Display Indication	Min	Max	Description
NFPA 110 ON	ON or OFF		See application note in section 18.30
HORN TIMEOUT 20"	5"	59'	The Horn (output #JC2) will automatically shutdown after time out. Program the option [OFF] in order to disable timeout; the only way to silence it is by using the [ACK-F1] button.
HOUR COUNT SET 0	0	65534	You can preset the Hour counter overwriting the old value. To cancel the Counter, put [0]

Table 12.07 PRESSURE INPUT		Table 12.08 TEMPERATURE INPUT (*)		Table 12.09 FUEL INPUT	
POINT 1 BAR 0 OHM 10	You are allowed to edit 6 value for the Oil pressure in the range 0-20.0Bar and 6 value for the resistance (OHM units) up to 1000 OHM	POINT 1 °C 128 OHM 19	You are allowed to edit 6 value for the Temperature in the range 0-250°C and 6 value for the resistance (OHM units) up to 1000 OHM (* Note)	POINT 1 LEVEL 0 OHM 10	You are allowed to edit 6 value for the Fuel Level in the range 0-99% and 6 value for the resistance (in OHM units) up to 1000 OHM
POINT 2 BAR 2.0 OHM 51		POINT 2 °C 115 OHM 26		POINT 2 LEVEL 0 OHM 10	
POINT 3 BAR 4.0 OHM 86		POINT 3 °C 90 OHM 46		POINT 3 LEVEL 0 OHM 10	
POINT 4 BAR 6.0 OHM 122		POINT 4 °C 80 OHM 67		POINT 4 LEVEL 0 OHM 10	
POINT 5 BAR 8.0 OHM 152		POINT 5 °C 70 OHM 95		POINT 5 LEVEL 50 OHM 95	
POINT 6 BAR 10.0 OHM 180		POINT 6 °C 40 OHM 287		POINT 6 LEVEL 99 OHM 180	
4MA BAR 0.0 20MA BAR 10.0	You can edit the correspondent value for mA or Volt.	4MA °C 0 20MA °C 200	You can edit the correspondent value for mA or Volt.	4MA LEVEL 0 20MA LEVEL 99	You can edit the correspondent value for mA or Volt.
0V BAR 0.0 10V BAR 10.0		0V °C 0 10V °C 200		0V LEVEL 0 10V LEVEL 99	

(*) Be2K-Plus supports 3 different response curve for: Aux Temperature, Oil Temperature & Coolant Temperature.

Section 12.10 [CONFIGURABLE INPUTS] submenu

Display Indication	Options	Note
INPUT 1 OPTION 0 INPUT 1 POLARITY N.O.	See the table 12.10 for the available options. You can select N.O. (normally open) or N.C. (normally closed).	Terminal #JF2
INPUT 2 OPTION 0 INPUT 2 POLARITY N.O.		Terminal #JF4
INPUT 3 OPTION 0 INPUT 3 POLARITY N.O.		Terminal #JF6
INPUT 4 OPTION 0 INPUT 4 POLARITY N.O.		Terminal #JF7
INPUT 5 OPTION 0 INPUT 5 POLARITY N.O.		Terminal #JF10
ALARM 1 CONTACT N.O. ALARM 2 CONTACT N.O.	Normally open or closed. Alarm 1 (Input #JF1) is ignored during the ALARM BYPASS timing (Section 12.03A). Alarm 2 (Input #JF8) is always active. We recommend that you use this input for EMERGENCY stop.	

Table 12.10: List of options for [CONFIGURABLE INPUTS]

Option	Description	Option	Description
[0]	Disables the input	[18]	External Display [↑] Pushbutton
[1]	Immediate Stop	[19]	External Display [↓] Pushbutton
[2]	Bypass and Stop (Note 4)	[20]	KG Status (feedback form the contactor of the Generator)
[3]	Cooling and Stop	[21]	KM Status (feedback form the contactor of the Mains)
[4]	Bypass + Cooling and Stop	[22]	KG Control (it closes the contactor overriding all controls)
[5]	Warning only (Note 1)	[23]	KM Control (it closes the contactor overriding all controls)
[6]	Bypass and Warning	[24]	IDLE SPEED (it holds the engine at IDLE speed)
[7]	Remote Manual Mode (Note 2)	[25]	Remote engine Start (It starts the engine only)
[8]	Remote Auto Mode (Note 2)	[26]	Remote Genset Start (It starts and transfer the Load)
[9]	Remote Off Mode (Note 2)	[27]	Reserve Generator
[10]	Remote LOCK (see 13.02B)	[28]	Master Generator
[11]	Generator simulated ON. It simulates the presence of the Generator	[29]	Overload (it opens the KG and shuts down the engine after a cooling down time).
[12]	Mains Simulated ON	[30]	KG feedback in Dual Set Mode
[13]	EJP function (Note 3)	[31]	[START] External pushbutton (works only in manual mode)
[14]	Remote Lamp test for NFPA-110 (see 18.30)	[32]	[STOP] External pushbutton (always active)
[15]	Horn Silence		
[16]	Display [→] Pushbutton		
[17]	Display [←] Pushbutton		

(Note 1) The Be2K-Plus detects the alarm if the engine is running. **(Note 2)** We recommend that you use an AUTO-OFF-MAN switch.

(Note 3) When the input is activated, the Be2K-Plus starts the engine. After a programmable time (see section 7.02), the KG will close. When the input is opened, the KG opens after a programmable time and the engine will stop after cooling down time.

(Note 4) For the programming of the BYPASS timing, see section 12.03A.

Section 12.11 [CONFIGURABLE OUTPUTS] submenu

Display Indication	Terminal	Options	Display Indication	Terminal	Options
OUTPUT 1	0	#JB1	OUTPUT 4	0	#JB4
OUTPUT 2	0	#JB2	OUTPUT 5	0	#JB5
OUTPUT 3	0	#JB3			
		[0] - [79]			[0] - [79]
		see table			see table
		12.11			12.11

Table 12.11A List of the options for [CONFIGURABLE OUTPUTS]

Option & description		Option & description	
[0]	The Output is disabled	[28]	Fuel Reserve (Switch / Sensor)
[1]	Under Speed Shutdown	[29]	High / Low Fuel Warning (Sensor)
[2]	Over Speed Shutdown	[30]	Tank Empty shutdown
[3]	Pick-up Failure Shutdown	[31]	Sensor Failure Warning
[4]	Common speed alarms	[32]	Transfer Pump Output
		[33]	Common fuel alarms
[5]	Under Frequency Shutdown	[34]	Maintenance SERVICE 1,2 and 3
[6]	Over Frequency Shutdown	[35]	Alarm 1: shutdown (see 12.10)
[7]	Over Current / Short Circuit Shutdown	[36]	Alarm 2: shutdown (see 12.10)
[8]	Over Current Warning		
[9]	Over KVA Shutdown	[37]	Auxiliary Alarm 1-----5: Shutdown
[10]	Minimum KW Warning	[38]	Auxiliary Alarm 1-----5: Warning
[11]	Maximun KW Waring	[39]	Common Sensor Failure (JM1 - 2 - 3 - 4 - 5)
[12]	Phase Sequence Error Shutdown	[40]	Common input alarm ([37]+[38]+[39])
[13]	Reverse Power Shutdown		
[14]	Over / Under Voltage Shutdown	[41]	Presence of Nominal Mains Parameters
[15]	Overload (input option [29] Shutdown)	[42]	Presence of nominal Generator paramters
[16]	Alternator Failure Shutdown/Earth Failure	[43]	Mains Restore Timing / Mains Failure timing
[17]	Common Generator alarms	[44]	KG Contactor of the Generator closed
		[45]	KM Contactor of the Mains closed
[18]	Low Oil Pressure Warning /Sender Failure	[46]	Crank Delay (Start Warning)
[19]	Low Oil Pressure Shutdown (Switch input JF9 or from analog Input)	[47]	PURGE (gas engine valve control)
[20]	Common Oil Pressure alarms	[48]	Cooling Timing
		[49]	Warm up Timing
[21]	High Temperature Shutdown (Switch input JF3)	[50]	RENT Warning (<48h) or Rent expired
[22]	High Temperature Shutdown (Analog input: Oil / Coolant / Auxiliary)	[51]	Engine Running Status
[23]	Low / High Temperature Warning (Analog input: Oil / Coolant / Auxiliary)	[52]	Be2K-Plus in OFF MODE (Status)
[24]	Temperature Sensor Open (Oil / Coolant / Auxiliary)	[53]	Be2K-Plus in MANUAL MODE (Status)
[25]	Common Coolant Temperature alarms	[54]	Be2K-Plus in AUTO MODE (Status)
		[55]	Be2K-Plus in TEST MODE (Status)
[26]	High – Low Battery Voltage Warning	[56]	Be2K-Plus in LOCK MODE (input option [10])
[27]	Fuel Pump Timeout Warning		

(*) For the programming of the BYPASS timing for the engine alarms, see section 12.03A.

Table 12.11B [CONFIGURABLE OUTPUTS OPTIONS] submenu

Option & description		Option & description	
[57]	Fail to Start Shutdown	[69]	COMMON OF ALL ALARMS. The output energizes all the time there is an alarm in the Be2KP controller. To reset this output, you have to cancel the alarm totally.
[58]	Fail To STOP Shutdown	[70]	Reserve Output (Section 18.20)
[59]	Engine Belt Break Shutdown	[71]	Telecom Room Monitoring
[60]	Idle Speed Control (to Governor)	[72]	Crank Output repeat
[61]	Parameter or Memory Error	[73]	ECU enable 2 (Active in Manual, Auto, Test modes and during the stop solenoid time)
[62]	Clock Error or Periodic Test Error	[74]	KM Pulse to Close
[63]	Pre-Lube Pump or Start Delay Timing	[75]	KM Pulse to Open
[64]	ECU Enable 1 (Active when Fuel solenoid and Stop are activated)	[76]	KG Pulse to Close
[65]	ECU STOP command	[77]	KG Pulse to Open
[66]	CAN-BUS RED LAMP	[78]	Telecom Battery HIGH/LOW
[67]	CAN-BUS YELLOW LAMP	[79]	Room Temperature HIGH/LOW. See section 7.03 to set the 'ROOM °C LOW' and 'ROOM °C HIGH' limits. A bypass delay of 2 minutes is provided.
[68]	CAN-BUS Communication Failure		

Section 12.12 CAN BUS SETTING

This command allows you to interface with an ECU equipped engine. Once you enable the J1939, use the configuration software in order to install the driver for your engine (see the Be2k-J1939 User Manual).

Display Indication	Instructions
<p>MODEL OF ENGINE</p> <p>[-----]</p> <p>PUSH F3 TO EXIT</p> <p>PUSH F3 TO CONFIRM</p>	<p>A) - Use [↑] or [↓] to select the [CAN BUS SETTING] function</p> <p>B) - Push the [F3 →] button to enter the selection box [- -] (^).</p> <p>C) - Push the [↑] or [↓] button to choose the model according to your need (Perkins, Volvo and so on).</p> <p>D) - Push the [F3 →] to trigger the operation. The message [DONE] will appear.</p> <p>(^) You can push [F3 →] again if you want to quit the function.</p> <p>NOTE: REMOVE THE SUPPLY AND RESTART THE Be2K-Plus WHEN PROGRAMMING THE MODEL OF ENGINE</p>
<p>DONE</p>	

Section 12.13 RESTORE DEFAULTS (Factory settings)

Display Indication	Instructions (see section 12.00 for PARAMETER MENU)
<p>PUSH F3 TO EXIT</p> <p>PUSH F3 TO CONFIRM</p>	<p>A) - Use [↑] or [↓] to select the [RESTORE DEFAULT] function</p> <p>B) - Push the [F3 →] button to enter the operation (^).</p> <p>C) - Push the [↓] button to confirm the operation</p> <p>D) - Push the [F3 →] to trigger the operation. The message [DONE] will appear.</p> <p>(^) You can push [F3 →] again if you want to quit the function.</p>
<p>DONE</p>	

SECTION 13.0 - ALARMS, WARNINGS AND SHUTDOWNS

The Be2K-Plus features:

- A)** – a yellow LED that turns on in case of a warning and a red LED that turns on in case of a shutdown
- B)** - symbols and red LED, on the front panel, indicating the alarms of the engine (see figure 1)
- C)** - configurable Horn output (°) and specific outputs for indication of alarms
- D)** - descriptive messages for alarms with date, time and measurement information
- E)** - event history capable of recording 200 alarms and events (see section 5.06)
- F)** - a pushbutton to silence the Horn ([ACK-F1])
- G)** - a COMMON OF ALL ALARMS option for a programmable output (see OPTION 69 in section 12.11B).

(°) The terminal JC-2 drives an external HORN. To silence the HORN, push the [ACK-F1] pushbutton or wait for the [HORN TIMEOUT] to expire (see section 12.06). If the [HORN TIMEOUT] is set to [OFF], the only way to silence the Horn is by using the [ACK-F1] pushbutton.

Instructions in case of alarm(s):

- 1) Look at the front fascia and take note of RED indicators and messages on display.
- 2) Some alarms, in order to cool down the engine, shutdown the engine after a programmable delay. We recommend that you wait the complete stop of the engine
- 3) Push the [ACK-F1] pushbutton in order to acknowledge the alarm. Push the [OFF] button
- 4) Consult the following sections for further information
- 5) Remove the cause of the alarm
- 6) Restart the engine (see section 2.0)

Displayed messages	Description	LED	Section
13.01 - Clock and periodic test alarms			
CLOCK ERROR	Real time clock failure or wrong programming	Yellow	6.0
AUTOMATIC TEST FAILED	Automatic Periodic Test Fault or wrong programming		7.0
PARAMETER ERROR	Error in a parameter		12.00
MEMORY ERROR	Failure of the memory		18.40
CAN BUS ERROR	Failure of the CAN-BUS communication		12.12



13.02A - Emergency alarms & Shutdowns			
FRONT PANEL EMERGENCY	This alarm takes place if you push the [STOP] button when the Be2k-Plus is in AUTO	Red	1.0 Figure 1.0
ALARM 1 SHUTDOWN	ALARM 1 Shutdown: it stops after by-pass timing (input #JF-1)	Red	
ALARM 2 SHUTDOWN	ALARM 2 Shutdown: it stops immediately (input #JF-8)		
INPUT 1 WARNING (SHUTDOWN)	Input 1 Warning or Shutdown (input #JF-2) Note (°)	Red or Yellow	12.10
INPUT 2 WARNING (SHUTDOWN)	Input 2 Warning or Shutdown (input #JF-4) Note (°)		

Note (°) : you can trigger a programmable output by programming options [37], [38] or [40]

13.02B - Emergency alarms & Shutdowns			
INPUT 3 WARNING (SHUTDOWN)	Programmable Input 3 Warning or Shutdown (input #JF-6) Note (°)	Red or Yellow	
INPUT 4 WARNING (SHUTDOWN)	Programmable Input 4 Warning or Shutdown (input #JF-7) Note (°)		
INPUT 5 WARNING (SHUTDOWN)	Programmable Input 5 Warning or Shutdown (input #JF-10) Note (°)		
REMOTE LOCK	An input programmed with option [10] is active. The Be2K-Plus shuts down the engine if running. When you deactivate the input, the alarm resets automatically and Be2K-Plus will operate normally.	Red	

Note (°) : you can trigger a programmable output by programming options [37], [38] or [40]

13.03 - Miscellaneous engine alarms		LED	Section
PICK UP FAILURE	Failure in detecting the signal from Pick-up (shutdown)	Red	12.04
OVER SPEED SHUTDOWN [*]	Over Speed shutdown		
UNDER SPEED SHUTDOWN [*]	Under Speed shutdown		
LOW BATTERY WARNING [*]	Low Battery Voltage warning: 11,8 for 12V battery and 23,6 for 24V battery.	Yellow	-
HIGH BATTERY WARNING [*]	High Battery Voltage warning:15V for 12V battery and 30V for 24V battery.		
FAIL TO START	Starting Failure shutdown	Red	12.03A
FAIL TO STOP	Fail to stop shutdown		
ENGINE BELT BREAK	Engine Belt break shutdown (Charger Failure)		

13.04 - Alternator and Contactors alarms			
OVERLOAD SHUTDOWN	Overload shutdown (input with option [29])		12.02A 12.02B
SHORT CIRCUIT [*]	Short circuit shutdown		
UNDER VOLTAGE [*]	Under Voltage shutdown		
OVER VOLTAGE [*]	Over Voltage shutdown		
PHASE UMBALANCE [*]	Phase unbalance shutdown		
UNDER FREQUENCY [*]	Under Frequency shutdown		
OVER FREQUENCY [*]	Over Frequency shutdown		
OVER KVA SHUTDOWN [*]	Over Apparent power shutdown		
PHASE SEQUENCE ERROR	Generator Phase sequence shutdown		
OVER CURRENT WARNING [*]	Over Current warning		
OVER CURRENT SHUTDOWN [*]	Over Current shutdown		
ALTERNATOR FAIL	Alternator Failure shutdown		
EARTH FAILURE	Earth Failure shutdown		
REVERSE POWER [*]	Reverse Power Shutdown		
KM FAILURE	The Mains contactor failed to work	Yellow	Options [20][21] (Table 12.10)
KG FAILURE	The Generator contactor failed to work		

[*] Note: the display records the value of the measurement in the moment the parameter triggers the alarm.

13.05 - Temperature alarms		LED	Section
TEMPERATURE SWITCH	Temperature input #JF-3. The engine stuts down in case of high engine temperature.		-
HIGH COOLANT WARNING [*]	Coolant alarm. Monitoring of Low temperature is active even if the engine is not running. High temperature monitoring works only if engine is running. (see option 21---25 for programmable outputs)	 Red or Yellow	12.03B & 12.03C
LOW COOLANT WARNING [*]			
COOLANT °C SHUTDOWN [*]			
OIL °C WARNING [*]	Abnormal Temperature of the OIL; Warning or / and Shutdown.	Red or Yellow	12.03B & 12.03C
OIL °C SHUTDOWN [*]			
AUX °C WARNING [*]	Abnormal Auxiliary Temperature. (Room temperature or other); Warning or / and Shutdown.	Yellow	12.03B & 12.03C
AUX °C SENDER SHUTDOWN [*]			
COOLANT SENDER OPEN			
OIL °C SENDER OPEN	Indicate the failure of a temperature sensor.	Yellow	
AUX °C SENDER OPEN			

[*] Note: the display records the value of the measurement in the moment the parameter triggers the alarm.

13.06 - Fuel Level alarms		Led	Section
LOW FUEL WARNING [*]	Low Level Fuel warning.	Yellow	12.05
HIGH FUEL WARNING [*]	High Level Fuel warning.		
FUEL RESERVE SWITCH	Level Low Warning (from level switch input JF5)		
FUEL RESERVE SENDER	Level Low Warning (from level sender)		
TANK EMPTY SWITCH	Be2k-Plus shuts down the engine if the level drops (level switch) below the limit for more than the programmed time.	 Red	12.05
TANK EMPTY SENDER	Be2k-Plus shuts down the engine if the level drops (level sensor) below the limit for more than the programmed time.		
PUMP TIMEOUT WARNING	This warning energizes if the PUMP to fill the tank remains activated for more than the programmed time.	Yellow	
FUEL SENDER OPEN	Failure of the Fuel Sensor (warning)		

[*] Note: the display records the value of the measurement in the moment the parameter triggers the alarm.

13.07 - Oil Pressure alarms			
LOW OIL BAR WARNING [*]	Low Oil Pressure Warning	Yellow	12.03B
LOW OIL BAR SHUTDOWN [*]	Low Oil Pressure Shut down		
LOW OIL JF9 SHUTDOWN	Low Oil Pressure Shut down (Switch input #JF9)		
PRESSURE SENDER OPEN	Failure of the Oil Pressure sender.	Yellow	

13.08 - Service and Rent Contract alarms		LED	Section
MAINTENANCE TIMER 1	Maintenance 1 & 2 provide a warning after timeout. Maintenance 3 provides a shutdown after timeout. To cancel the alarm, reprogram the Maintenance or simply enter & exit the MAINTENENCE menu to restart the count.	Yellow	8.0
MAINTENANCE TIMER 2			
MAINTENANCE TIMER 3			
RENTAL WARNING	Less than 48 hours remaining before engine shutdown.	Yellow	7.02
RENTAL EXPIRED	Rental period termination. To cancel the alarm, reprogram the RENTAL or simply enter & exit the TEST & RENTAL program menu to restart the count	Red	
MAX RUN TIME	Time expired. This timer allows the engine to run a limited number of hours. If case of alarm, verify the general status of the engine, cancel the alarm and restart the engine. In MAN mode the timeout is disabled and the engine runs for unlimited time. Before entering the AUTO mode select the OFF mode to reset the timer.		

13.09 - Telecom alarms (Room ambient temperature e Battery voltage)			
TELECOM °C LOW	These alarms allow you to monitor the Room Temperature (section 12.03C for analogue input programming) and voltage of the TELECOM equipment (section 7.03). You can set the output option [79] for temperature and [78] for Telecom Battery monitoring.	Yellow	Table 12.10 sections 12.03C 7.00
TELECOM °C HIGH			
TELECOM V HIGH			
TELECOM V LOW			

SECTION 14.0 - ENGINE RUNNING DETECT

The B2K-Plus inhibits the starter motor when the engine starts running. When the engine is not running, voltage in the terminal D+/WL of the charger alternator (input JC-10) is 0V. When the engine starts running, the voltage of the D+/WL terminal increases; the range to disconnect the starter motor is between 6V to 10V. The default parameter of [CHARGER VOLTAGE] (section 12.03A) is 8.0V. For 24V batteries, we recommend that you set the threshold to 16V. For a safe use, be sure that the green 'ENGINE RUNNING' LED on the front panel is off during all of the starting attempts. The Charger Alternator voltage can be displayed in the 'Engine menu' as indicated in the section 5.04. In addition, Be2K-Plus monitors the Generator for disconnecting the crank motor. The insertion of switches or breakers in series to terminals #JA6-7-8 is not recommended; the Be2K-Plus will not detect the engine running condition from the Generator Voltage or Frequency (see CRANK TERMINATION in section 12.03A).

NOTE: THE 'ENGINE RUNNING' LED MUST BE LIT WHEN THE ENGINE RUNS. USING THE ENGINE WITHOUT THIS SIGNAL MAY BE DANGEROUS.

SECTION 15.00 - TROUBLESHOOTING GUIDE

Troubleshooting for Be2k-Plus is performed by selectively isolating the failure of the various circuit sections. We recommend that you disconnect the unit from the panel and set up the troubleshooting application circuit as indicated in section 15.01. This procedure should be carried out by qualified personnel only.

!! WARNING !!

High voltage is present inside this instrument. To avoid electric-shock hazard, operating personnel must not remove the protective cover. Do not disconnect the grounding connection. Any interruption of the grounding connection can create an electric shock hazard. Before making external connections, always ground the Be2K-Plus first by connecting the control panel to ground.

Section 15.01 Troubleshooting Set up Circuit

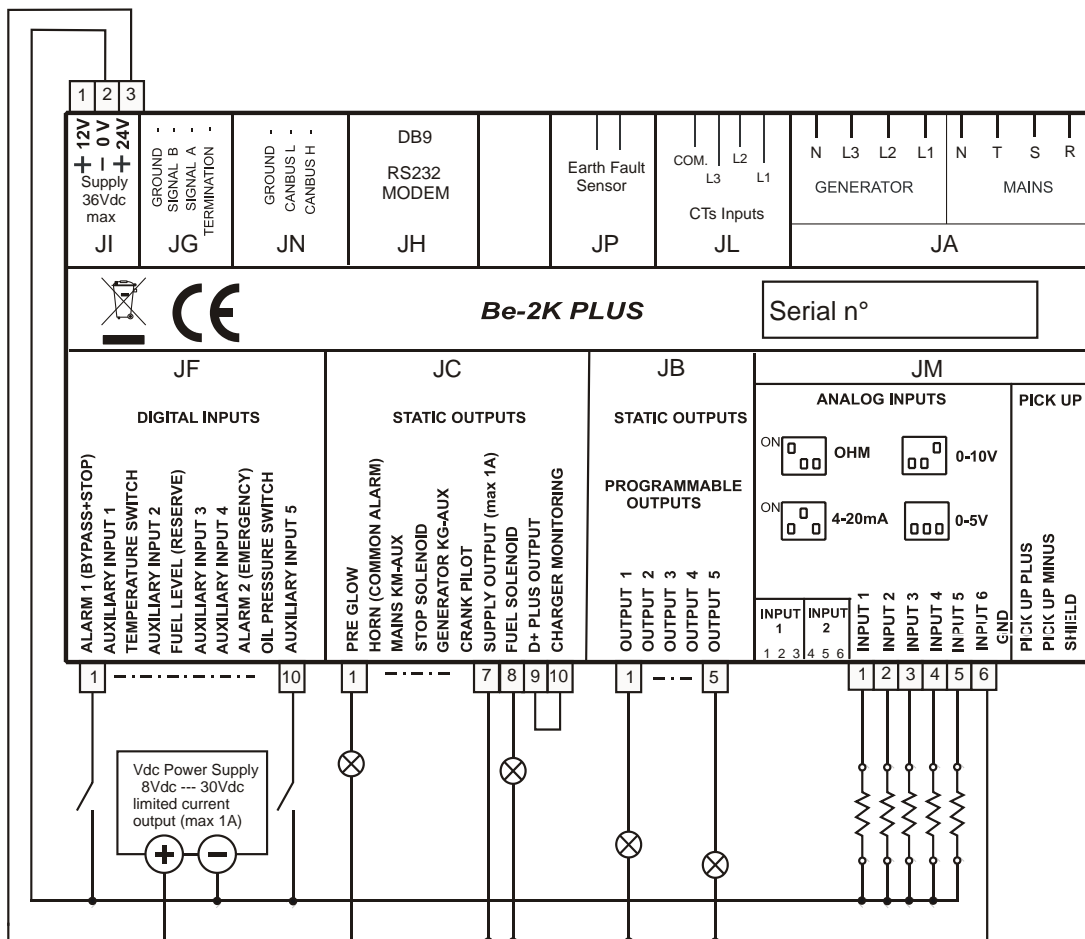

15.01 Testing the Pushbuttons

Follow the instructions:

- A)** - Remove the battery power supply; disconnect all connectors
B) - Push and hold the [ACK-F1] pushbutton, apply the Vdc power supply.
C) - Release the button; the message **[KEYS TEST]** will be displayed on the screen.
D) - Push the pushbuttons on the front panel one by one. The display will show a message according to Table 15.01. As soon as you release a button, the message disappears (no buttons activated)

Table 15.01: Pushbuttons true table

Pushbutton	Display Message	Pushbutton	Display Message
[START]	START	[AUTO]	AUTO
[STOP]	STOP	[ACK-F1]	ACK
[I - KG]	KG	[F2 ←]	LEFT
[O]	OPEN	[F3 →]	RIGHT
[I - KM]	KM	[F4 ↑]	UP
[MAN]	MANUAL	[F5 ↓]	DOWN
[OFF]	OFF		-

To exit the troubleshooting remove the Vdc power supply at anytime

15.02 Testing the Inputs

D) – Push [ACK-F1] pushbutton until the message **[INPUT TEST]** appears on display. Plug the connector JF. Connect to the battery minus, one by one, the inputs. For each input, a code will be displayed (see Table 15.02). If some inputs are connected simultaneously (in case of short circuit for example), the display will indicate the inputs that are activated together. When all inputs are disconnected the display must indicate only the message [INPUT TEST]

NOTE - At this stage, with all inputs disconnected, if the display indicates one of the codes contained in Table 15.02, the Be2K-Plus is damaged and should be returned to Bernini Design for repair.

Table 15.02

Terminal number (Function)	Display Code	Terminal number (Function)	Display Code
#JF-1 (Alarm1)	ALARM 1	#JF-6 (Programmable 3)	INPUT 3
#JF-2 (Programmable 1)	INPUT 1	#JF-7 (Programmable 4)	INPUT 4
#JF-3 (Temperature)	TEMP	#JF-8 (Alarm 2)	ALARM 2
#JF-4 (Programmable 2)	INPUT 2	#JF-9 (Oil Pressure)	OIL
#JF-5 (Fuel Reserve)	FUEL	#JF-10 (Programmable 5)	INPUT 5

To exit the troubleshooting remove the Vdc power supply at anytime

15.03 Testing the Outputs

- A) - Push the [ACK-F1] pushbutton, for about 10 seconds, until the message **OUTPUT TEST** appears.
- B) - Plug the connectors JC, JB as indicated in the section 15.01. At this stage, if a lamp turns on, the Be2K-Plus is damaged and should be returned for service.
- C) - Push in sequence, the pushbuttons as indicated in the Table 15.03. A message will indicate that the output is activated: the lamp connected should activate as long as you push and hold the button.

Table 15.03: Output true table Indicates the correspondence for each message. If a lamp fails to turn on or always remains activated, the Be2K-Plus is damaged and should be returned for service.

Pushbutton	Message	Output	Pushbutton	Message	Output
[START]	PREGLOW	JC1	[AUTO]	OUTPUT1	JB1
[STOP]	HORN	JC2	[F2 ←]	OUTPUT2	JB2
[I - KG]	KG	JC5	[F3 →]	OUTPUT3	JB3
[O]	STOP SOLENOID	JC4	[F4 ↑]	OUTPUT4	JB4
[I - KM]	KM	JC3	[F5 ↓]	OUTPUT5	JB5
[MAN]	CRANK	JC6			
[OFF]	FUEL SOLENOID	JC8		-	

15.04 Testing the Sensors

- A) - Push the [ACK-F1] pushbutton, for about 10 seconds, until the page of analog measurements appears.
- B) - Set the dip-switch for INPUT1 & 2 to 0 - 10 Vdc mode (OFF-OFF-ON).
- C) - Compare the indication with an external instruments. If the value indicated by the display is more than 3% (or less than 3%), the Be2K-Plus is damaged and should be returned for service.

Table 15.04 Analog measurements

Terminal number	Indication of the Display (°)	Recommended values for testing the measurements
#JM-1	IN 1: [XX.X] V	8 10 Vdc
#JM-2	IN 2: [XX.X] V	8 10 Vdc
#JM-3	IN 3: [XXXX] OHM	100-1000 Ohm
#JM-4	IN 4: [XXXX] OHM	100-1000 Ohm
#JM-5	IN 5: [XXXX] OHM	100-1000 Ohm
#JM-6	IN 6: [XX.X] V	8 10 Vdc
#JC-10	ALTERNATOR V [XX.X]	12.... 24 Vdc
#JI1-2-3	BATTERY V [XX.X]	12 24 Vdc

(°) Note [X--X] indicates a numerical field.

15.05 Testing the PICK UP Input

follow the instructions:

- A) - Push the [ACK-F1] pushbutton, for about 10 seconds, until the message [HZ-SPEED] will appear.
- B) - Apply a signal with a known frequency to PICK-UP input (300 up to 5000 Hz)
- C) - The display should indicate the frequency (Hz) with a maximum error of about 1%

To exit the troubleshooting remove the Vdc power supply at anytime

SECTION 16.00 - GENERAL SPECIFICATIONS

Supply voltage: 5.5Vdc to 36Vdc, 50-150mA **Protection:** internal 700mA thermal fuse.

Dimensions: 250mm X 185mm X 67mm. **Panel Cut-out:** 239mm X 171mm, indoor operation

Operating temperature range: -30 deg C up to +70 deg C. **Humidity range:** 5% up to 95% non-condensing.

Weight: 1400 gr. **General design:** ECC 89/336, 89/392, 73/23, 93/68, IEC 68-2-6 **Certification:** CE

Static outputs characteristics Output Current: 300mA/100Vdc short circuit proof. Logic: negative.

Supply output for relays (terminal JC7): Max 1A at V battery minus 1Vdc (short circuit proof).

Mains and Generator voltage Nominal Voltage input: 70 Vac-600Vac. Over voltage: 2KVac phase to neutral. Measurement precision: +/- 2%. Input impedance: 2 Mega Ohm

Mains and Generator Frequency Nominal Frequency input: 20-99Hz. Precision & Accuracy : 0.5%

Current transformer input size: 10/5Aac up to 9900/5Aac. Maximum admissible permanent current: 7Aac Measurement precision: +/- 2%. Internal resistance: 0.05 Ohm

Digital inputs: Open circuit voltage: Battery voltage minus 2V - Trigger level: < 2Vdc (max 15mA).

Pick-up inputs: 0.5-60Vac / 0-15.000Hz. Reading accuracy +/-1% (0-4000RPM).

Sensor inputs: Open circuit voltage: max 5V/max 15mA. Reading accuracy +/- 2%. (0-2000 Ohms).

Charger alternator monitoring: Operating voltage up to 36Vdc/3W. Vdc reading accuracy +/- 2%.

Measurements methods: True-RMS, Intelligent Average (DC), S.A.R., maximum error +/-2%.

Hour Run Counter & Timers: internal Quartz Crystal oscillator 5.00Mhz. Resolution 10mS; precision 0,10%

SECTION 17.00 - SOFTWARE UPGRADES & REVISIONS

Firmware Versions	Date	User manual	Description
1.00	Jan. 09	V200	CanBus upgrade-first release
1.84	Dec. 015	V200	<ul style="list-style-type: none"> - Modified output option [69]. No longer related to mains simulated. New function is the COMMON OF ALL ALARMS. To reset the output you are required to cancel all alarms. - Recovery of a 'LOST PASSWORD'. Simultaneously push [ACK]+[LEFT] during power on. The display will provide the recovery code. Send the code via e-mail to support@bernini-design.com - In MAN,AUTO & TEST mode of operations we removed the main menu. This menu is available only in OFF mode of operation. - Solved miscellaneous bugs related to the user interface.

SECTION 18.00 - APPLICATION NOTES

18.10 - Single Phase operation

- A)** - Program the parameter PHASE MODE for the Mains (section 12.01) to [1PHASE].
- B)** - Program the PHASE MODE for the Generator (section 12.02A) to [1PHASE].
- C)** - Connect Mains Live to #JA-1 and neutral to #JA-4.
- D)** - Connect Generator Live to #JA-5 and neutral to #JA-8. You are required to adjust the parameters Over/Under voltage according to your requirements. The indication of the Voltage L1-N will be displayed in the top part of the 7-segment red display (V1)

Note: Be2K-Plus allows mixed selections: Three-Phase Mains and Single Phase Generator or viceversa.

18.20 – Dual-Set Stand-by Generators

This configuration consists of two generators in stand by to Mains. You can set, by means of a switch, a **'Master Generator'** or **'Reserve Generator'**. When Mains fails, the **'Master Generator'** starts and supplies the Load. After a programmed [DUAL SET RUN TIME] (section 7.02), **Reserve Generator** will start and supply the Load; **Master Generator** will stop after a cooling down time. In case of failure, the other set will start immediately. Figure 18.20 illustrates the concept. You are required to wire the controllers as indicated in the figure 18.20 and program the parameters as follows:

INPUT OPTION PROGRAMMING		OUTPUT OPTION PROGRAMMING	
INPUT 1	[28] Master Generator	OUTPUT 1	[70] Output Reserve Generator
INPUT 2	[27] Reserve Generator	OUTPUT 2	[69] Mains Simulated
INPUT 3	[12] Mains simulated	<u>Note: select the Master and Reserve Generator and enter the AUTO mode on each controller</u>	
INPUT 4	[30] KG Feedback (dual set Mode)		

Note: for a proper working of 'Dual Set Mode' we recommend that you program the parameters [MAINS BREAKER], [MAINS FAILURE] and [MAINS RESTORE] over 5 seconds (see section 12.01)

Figure 18.20 – Dual-Set Standby Generators wiring diagram

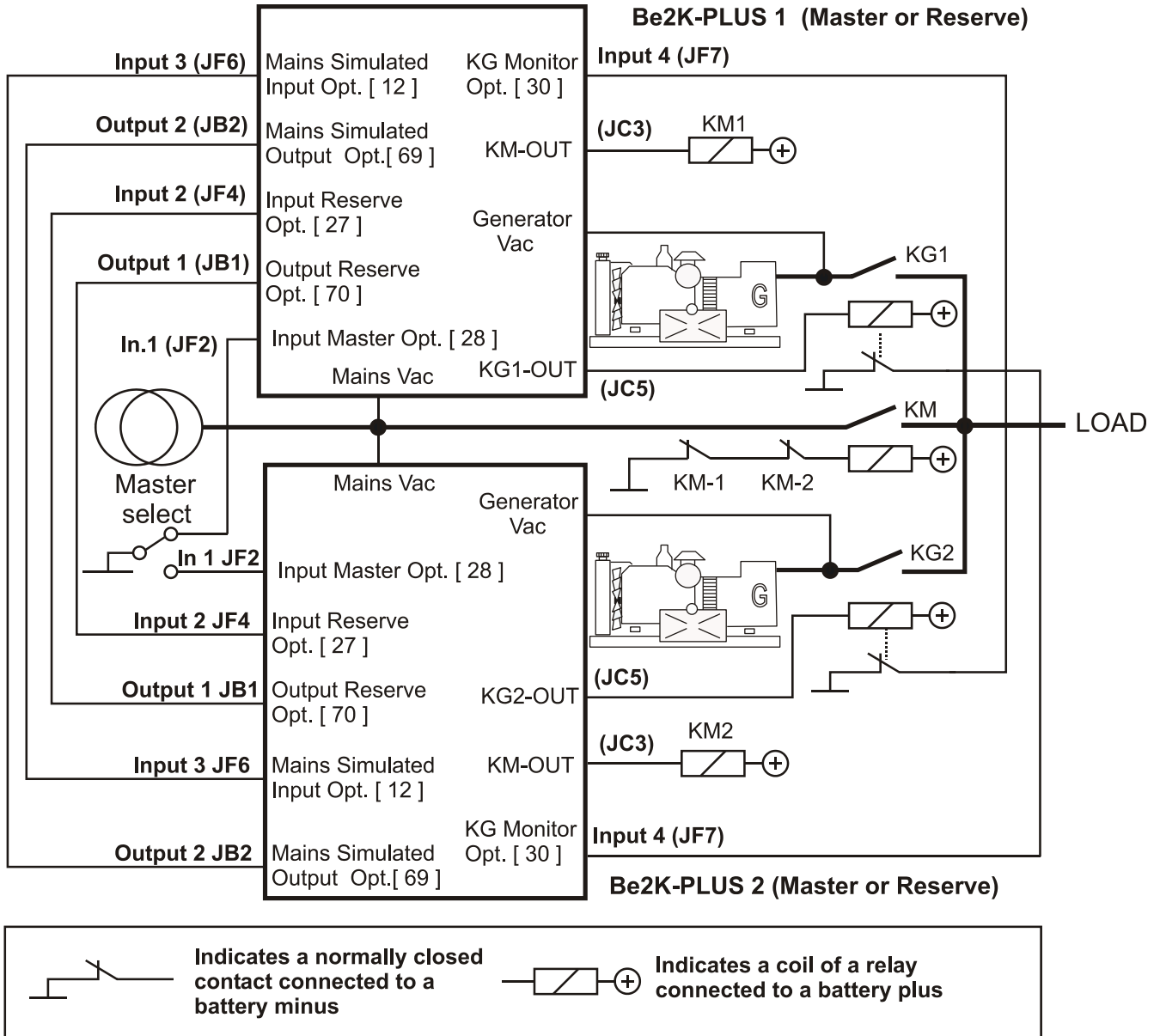

18.30 – NFPA110 MODE, BASIC INFORMATION

To comply with the NFPA110 standard, the ON option in the parameter [NFPA 110] (see section 12.06) needs to be enabled. It is then required to perform the following basic operations:

- Install an external 3-position switch **RUN-OFF-AUTO** for selecting the Mode of operation
- Connect the 'RUN' terminal of the switch to a programmable input with option [26] (Remote Genset start)
- Connect the 'AUTO' terminal of the switch to a programmable input with option [8] (Remote Auto Mode)
- Connect the 'OFF' terminal of the switch a programmable input with option [9] (Remote Off Mode).
- Connect the other side of the RUN,OFF and AUTO contacts to the battery minus.
- Connect a relay to the terminal #JB1 (Programmable output 1) in order to drive a lamp. The lamp turns on if the Be2k-Plus is **NOT IN AUTO MODE** (use the normally closed contact of the relay)
- Program the Output 1 with the option [54] (See Table 12.11, Be2K-Plus in AUTO mode status)
- Program one input with option [14] (Remote Lamp test) and connect an external pushbutton.
- Consult the NFPA110 documentation and verify if other settings are required.

18.40 – MEMORY ERROR

The message [**MEMORY ERROR**] indicates a failure of the Memory or DATA corruption. In order to clear the alarm, follow the instructions below:

- (**A**) – Remove the power supply for a minute.
- (**B**) – Reconnect the power supply. If the message disappears you can continue using the controller without problem.

If the message persists on the display, follow these instructions

- (**C**) – Push the [ACK-F1] pushbutton in order to cancel the alarm
- (**D**) – Enter the Programming (see section 9.0)
- (**E**) – Select the function CLEAR MEMORY. If the message [DONE] appears, you can reprogram the controller. If the Be2k-Plus returns the message [MEMORY ERROR], the controller is damaged and should be returned to Bernini Design for service

SECTION 19.00 - PANEL & GEN-SET BUILDERS NOTES

SECTION 20.00 - TYPICAL APPLICATION

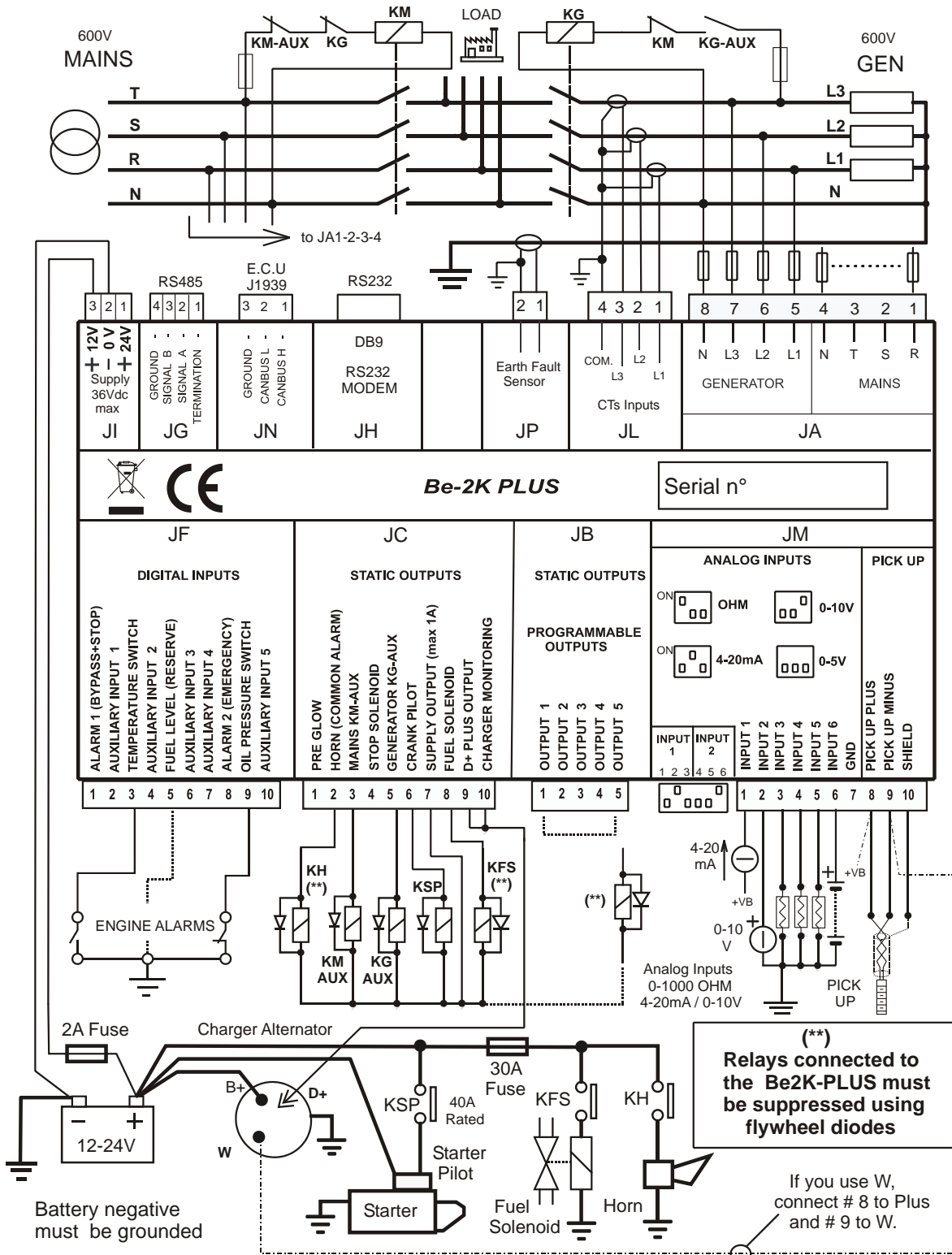

SECTION 21.00 - REAR VIEW AND DIMENSIONS

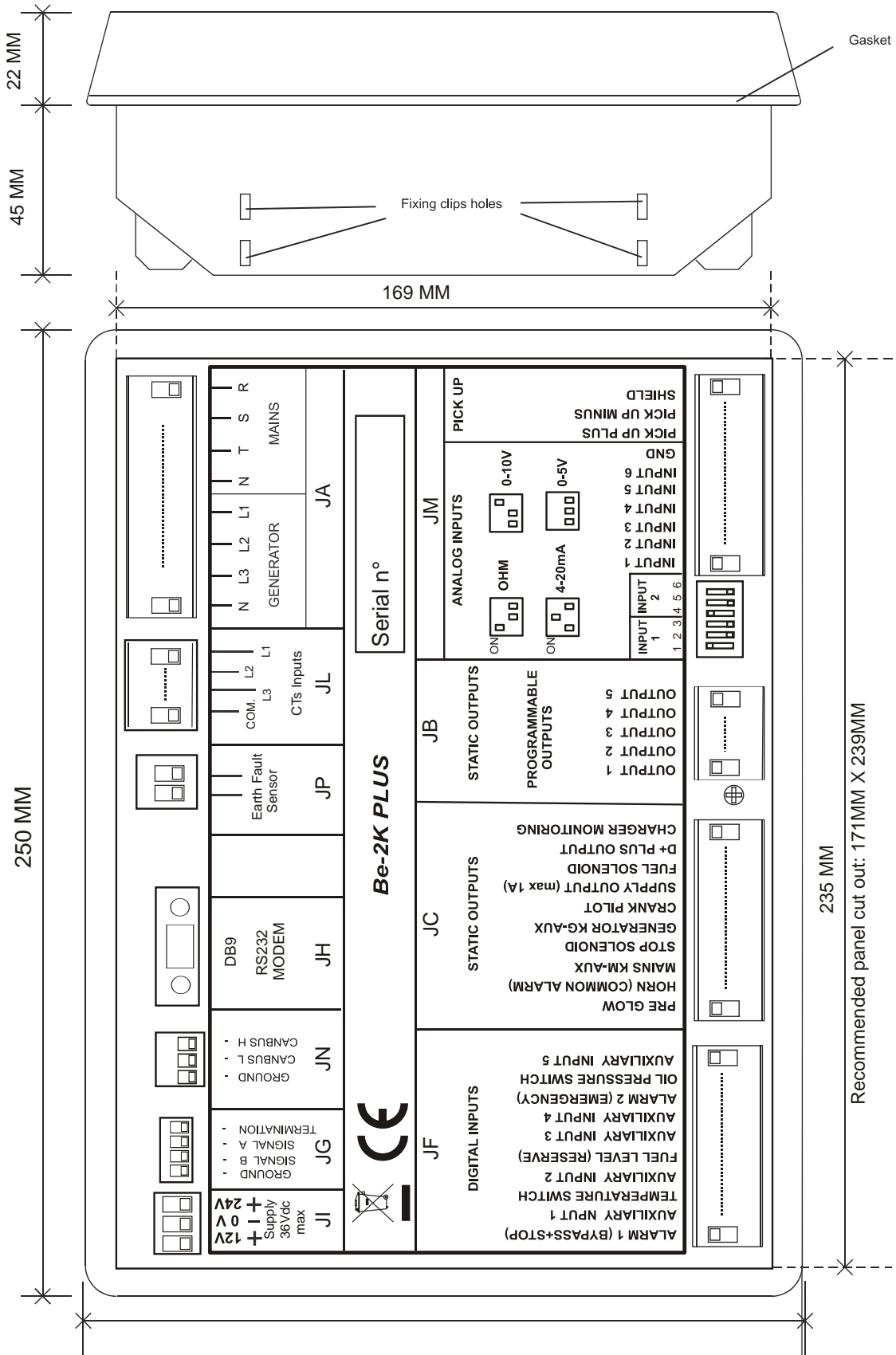

SECTION 22.00 - TERMINAL DESCRIPTION**!! WARNING !!**

ANY INTERRUPTION OF THE PROTECTIVE GROUND OR DISCONNECTION OF THE PROTECTIVE EARTH IS LIKELY TO MAKE THE Be2K-Plus DANGEROUS

Terminal	Description & Notes		
#JA-1	Mains voltage 600Vac	R	Inputs for Mains and Generator monitoring up to 600Vac. Neutral connection is not a mandatory requirement (but provides improved measurement precision)
#JA-2		S	
#JA-3		T	
#JA-4		Neutral	
#JA-5	Generator voltage 600Vac	L1	For Single Phase operation use terminals R/Neutral for the Mains and L1/Neutral for the Generator (see also section 18.10)
#JA-6		L2	
#JA-7		L3	
#JA-8		N	

#JB-1....5	Programmable Out 1....5. All outputs are solid state battery negative (max300MA). The options for these outputs are listed in the table 12.10.
------------	--

#JC-1	Preglow output	See section 12.03A and Figure 12.03A for programming
#JC-2	Common alarms output	[HORN TIMEOUT] programmable time (see 12.06)
#JC-3	Contacteur of the Mains output	It drives the Auxiliary relay of the KM (see 20.00)
#JC-4	Stop Solenoid output	Energized to stop. See 12.03A for programming
#JC-5	Contacteur Generator output	It drives the Auxiliary relay of the KG (see 20.00)
#JC-6	Crank Pilot output	It drives the Starting Motor. See [CRANK TIME] on section 12.03A.
#JC-7	Output supply for external relays.	It provides supply for the common of the output relays (max current 1A). The voltage is V Battery minus 0,5V.
#JC-8	Fuel Solenoid output	Energized to run output for Fuel solenoid and ancillary circuitry.
#JC-9	Alternator Excitement output	Connect JC9 and JC10 together with D+/W.L. of Charging Alternator (See section 12.03A).
#JC-10	D+ /W.L. (monitoring input)	

See section 12.10 and Table 12.10 for the available options for the following digital inputs (switch to negative)

#JF-1	Alarm 1	It triggers after the <u>ALARM BYPASS (*)</u> and stops the engine after a cooling down time.
#JF-2	Auxiliary Input [1]	Programmable input. Default: [0] = Not used
#JF-3	Temperature Switch	It triggers after the <u>ALARM BYPASS(*)</u> and stops the engine immediately.
#JF-4	Auxiliary Input [2]	Programmable input. Default: [0] = Not used
#JF-5	Fuel Reserve Switch	This input activates the Fuel reserve warning. It can stop the engine after a programmable time (see 13.06).
#JF-6	Auxiliary Input [3]	Programmable input. Default: [0] = Not used
#JF-7	Auxiliary Input [4]	Programmable input. Default: [0] = Not used
#JF-8	Alarm 2	Alarm 2 stops the engine immediately. It can be used as Emergency Stop.
#JF-9	Low Oil Pressure Switch	Oil Pressure Switch with normally closed contact. It triggers after the engine <u>ALARM BYPASS(*)</u> timing.
#JF-10	Auxiliary Input [5]	Programmable input. Default: [0] = Not used

(*) To program the engine [ALARM BYPASS] timing see section 12.03A.

#JG-1	Termination 120 OHM	RS485 serial interface. Consult the Be2K-Plus communications User Manual for further information.
#JG-2	SIGNAL A	
#JG-3	SIGNAL B	
#JG-4	Common Ground	

#JH-1-8-9	Not used	RS232C interface. 9 Poles Sub-D MALE Consult the Be2K-Plus communications User Manual for further information.
#JH-2	RX Line	
#JH-3	TX Line	
#JH-4	DRT output	
#JH-5	Common Ground	
#JH-6	DSR Input	
#JH-7	Internal Pull-UP	

#JI-1	+24V Battery Vdc supply	An internal Electronic 500mA Thermal Protection is provided. Terminals 1 or 3 supplies the common of relays for the static outputs (terminal #JC7)
#JI-2	Battery minus connection	
#JI-3	+12V Battery Vdc supply	

#JL-1	Current Transformer L1 (S2)	Inputs for the Current Transformers. The nominal Current is 5A. See also the sections 22.0, 12.02A, 12.02B S1 terminal of each CT must be grounded
#JL-2	Current Transformer L2 (S2)	
#JL-3	Current Transformer L3 (S2)	
#JL-4	Current Transformer Common	

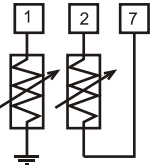
#JM-1	Analog Input 1	Senders, 4-20mA or 0-5V, 0-10V Senders	In case of floating sender, connect the signal return to terminal #JM 7. You can connect, mA or V transmitters to INPUT 1 and 2 (see 12.03B and 12.05). You are required to set the switch according to the programming option (OHM / mA or 0-5/10V) for each input as follow: 
#JM-2	Analog Input 2		
#JM-3	Analog Input 3		
#JM-4	Analog Input 4		
#JM-5	Analog Input 5		
#JM-6	Analog Input 6 (0-60VDC, see section 7.02)		Note: #JM6 mode is 0-60Vdc for Telecom Battery Monitoring. Refer also to www.bernini-design.com support area and application notes.
#JM-7	Analog ground for 2-wires sender. Example:  <p>Sensor '1' is one wire sender and Sensor '2' is a 2-wires sender</p>		
#JM-8	Pick-Up (+) signal 'high' input	In case of 'W', connect the Pick-Up (+) input to the Battery plus and connect 'W' to pick-Up (-). You are required to set the tooth count (see section 12.04)	
#JM-9	Pick-Up (-) signal 'low' or 'W'		
#JM-10	Connection for the shield		

#JN-1	TERMINATION	CAN BUS serial interface. Consult the Be2K-Plus CAN-BUS User Manual for further information.
#JN-2	CAN BUS H	
#JN-3	CAN BUS L	
#JN-4	CAN BUS Ground	

#JP-1	Current transformer for Earth Fault sensing	See section 12.02B
#JP-2		