

# BE242 INSTALLATION MANUAL

The information in this document about the BE242 controller may be subject to change without prior notice. Bernini Design assumes no responsibility for any errors that may appear in this instruction manual or in the wiring diagrams.

Although Bernini Design has taken all possible steps to ensure that the User Manual is complete, bug free and up-to-date, we accept that errors may occur. If you encounter problems with this instruction manual, please contact us.

## Customer Support

e-mail: [bernini@bernini-design.com](mailto:bernini@bernini-design.com)

mobile: +39 335 70 77 148 mobile: 0040 721 241 361

## Warranty

Bernini Design SRL (hereinafter "BD") warrants that Be242 CONTROLLER shall be free from defect in material or workmanship for a period of 3 years from the BD delivery date. BD shall, at its discretion, repair or replace the product without charge. The buyer shall provide sufficient information on any alleged defects in the product, so as to enable BD to determine their cause and existence. If the Be242 is not defective, or the product is defective for reasons other than covered by this warranty, the buyer will be charged accordingly. This warranty shall not apply if the Be242 has not been used in accordance with the User Manual and other operating instruction, particularly if any defects are caused by misuse, improper repair attempts, and negligence in use or handling.

This CONTROLLER complies with EMC protection requirements



## **WARNING!!**

High voltage is present inside the **BE242 CONTROLLER**. To avoid electric-shock hazard, operating personnel must not remove the protective cover. Do not disconnect the Earth connection. The Be242 can start the engine at anytime. Do not work on equipment, which is controlled by the **BE242 CONTROLLER**. When servicing the engine, disconnect the battery and battery charger. We recommend that warning signs be placed on equipment indicating the above.

**BE242 controller alphabetic index**

<p><b>Alternator Failure E04 ..... 7.02B [P.15]</b>  <b>Alarms..... 4.10, 8.0</b>  <b>Alarm output control..... 7.09, [39]</b>  <b>Alarm inputs ..... 7.06, 8.0</b>  <b>Automatic..... 2.3</b>  <b>Battery, Alarms..... 4.10 [Er.13]</b>  <b>Belt break ..... 4.10 [Er.02]</b>  <b>Choke, control ..... Table 7.03 [P.22]</b></p> <p><b>Characteristics..... 14.0</b>  <b>Charger Alternator..... 11.0, 7.03 [P.26]</b>  <b>Clear the memory ..... 12.3</b>  <b>Contactors..... 2.21, 18.0</b>  <b>Connectors, Plugs ..... 19.0</b></p> <p><b>Crank timing ..... 7.03A [P.19]</b>  <b>Current Transformer ..... 7.02B [P.18]</b>  <b>Cooling down time ..... 7.03A [P.24]</b>  <b>Defaults..... 6.20</b>  <b>Dimensions..... 19.0</b>  <b>Display ..... 3.0</b>  <b>Display Messages ..... 4.10, 4.20</b>  <b>Er.0--8.. Error codes ..... 4.10</b>  <b>[FAIL] Memory error..... 4.10 [FAIL]</b>  <b>Engine Running..... 11.0</b>  <b>Emergency input ..... 4.10[Er.08]</b>  <b>Events..... 4.30</b>  <b>Fail to Start ..... 4.10[Er.11], P.34</b>  <b>Fail to Stop..... 4.10[Er.07]</b>  <b>Front Panel ..... 1.0 Figure 1</b>  <b>Frequency ..... 7.02A [P.11][P.12]</b>  <b>Fuel Level..... 7.04 [P.36]</b>  <b>Generator Voltage ..... 7.02 [P.9] [P.10]</b>  <b>Generator Frequency ..... 7.02 [P.11] [P.12]</b>  <b>Generator Failure E04 ..... 7.02B [P.15]</b>  <b>Glow Plugs..... 7.03 [P.22]</b>  <b>Hi-U, Over Voltage..... 7.02A [P.10]</b>  <b>Hour Counter ..... 9.0</b>  <b>Horn Programming..... 7.05 [P.50]</b>  <b>Inputs (Programmable) ... 7.06, 7.07</b></p> <p><b>LED, LEDs..... 5.0, 2,21, 2.3</b>  <b>Lamp Test ..... 5.1</b>  <b>Lo-U, Under Voltage..... 7.02A [P.09]</b>  <b>Lock, Remote Lock E03 .. 4.10</b>  <b>Low Battery voltage ..... 4.10,[Er.13]</b>  <b>Log Events.....4.30</b>  <b>Mains Failure ..... 7.01A [P.01]</b>  <b>Mains Restore..... 7.01B [P.02]</b>  <b>Maintenance timers..... 7.05, 16.40</b>  <b>Mains Simulation..... 7.07 [15]</b></p>	<p><b>Measurements.....3.0</b>  <b>Memory clear..... 12.3</b>  <b>Memory Events.....4.30</b>  <b>Messages (Display)..... 4.0</b>  <b>Manual.....2.2</b></p> <p><b>Outputs (programmable) ... 7.09</b>  <b>Operation modes.....2.0</b>  <b>Overload ..... 4.10 [Er.05]</b>  <b>Overload (external)..... 7.07 [20][21]</b>  <b>Over Frequency..... 4.10 [Er.01]</b>  <b>Over Voltage HI-U..... 4.10 [HI-U]</b></p> <p><b>Parameters ..... 7.0</b>  <b>Password..... 6.40</b>  <b>Parameters reading..... 6.30</b>  <b>Periodic test..... 7.05 [P.41][P.42]</b>  <b>Program, Programming ..... 6.0</b>  <b>Pre Glow ..... 7.03[P.22]</b>  <b>Pump Set control ..... 10.0</b>  <b>Power Supply ..... 14.0</b>  <b>Push buttons ..... 2.0, 2.2</b></p> <p><b>Rest time..... 7.03A [P.21]</b>  <b>Rental Programming ..... 7.05 [P.47]</b>  <b>R.P.M.....7.02B [P.16]</b></p> <p><b>Settings (Parameters) ..... 7.0</b>  <b>Service timers..... 7.05, 16.40</b>  <b>Single Phase operation..... 16.30</b>  <b>Specifications..... 14.0</b>  <b>Start.....2.2</b>  <b>Start Attempts ..... 7.03B [P.31]</b>  <b>Starting Failure..... 4.10 [Er.11]</b>  <b>Stop, Stop solenoid..... 7.03A [P.25]</b></p> <p><b>Temperature ..... 7.03B [P.30]</b>  <b>Terminal description ..... 19.0</b>  <b>Test, Remote Test ..... 7.07 [10] [11]</b>  <b>Test mode.....2.4</b>  <b>Transformer, Current ..... 7.02B [P.18]</b>  <b>Troubleshooting..... 13.0</b></p> <p><b>Under Voltage Lo-U..... 7.02A [P.09]</b>  <b>Under Frequency..... 7.02A [P.11]</b>  <b>Voltage measurements ..... 3.0</b>  <b>Warm-Up time..... 7.03A [P.23]</b>  <b>Wiring diagram ..... 18.0</b></p>
--	--

## - Contents-

<b>1.0 Introduction</b> .....	<b>page 4</b>
<b>2.0 Selection of a Mode of operation</b> .....	<b>page 4</b>
2.1 OFF mode.....	page 5
2.2 MANUAL mode.....	page 5
2.3 AUTO mode.....	page 6
2.4 TEST mode.....	page 6
2.5 PROGRAM mode .....	page 6
2.6 TROUBLESHOOTING mode .....	page 6
<b>3.0 DISPLAY measurements</b> .....	<b>page 7</b>
<b>4.0 DISPLAY messages and Log Events</b> .....	<b>page 8</b>
4.10 Alarm Messages.....	page 8
4.20 Miscellaneous Messages .....	page 8
4.30 Log Events / Memory Events.....	page 9
<b>5.0 LED indicators description</b> .....	<b>page 9</b>
5.1 Lamp and Display Test .....	page 9
<b>6.0 PROGRAMMING &amp; READING parameters</b> .....	<b>page 9</b>
6.10 Enter the Programming Mode.....	page 9
6.11 Enter the password.....	page 9
6.12 Programming .....	page 10
6.13 Saving.....	page 10
6.14 Exit without saving .....	page 10
6.20 Re-programming default settings .....	page 10
6.30 Reading the parameters .....	page 10
6.40 Activating the password.....	page 11
6.50 Changing the password.....	page 11
6.60 Removing the password .....	page 11
6.70 Loosing the password.....	page 11
<b>7.0 Programmable Paramètre</b> .....	<b>page 11</b>
Table <b>7.01A-B</b> Mains Failure Control.....	page 12
Table <b>7.02A-B</b> Generator Parameters .....	page 13
Table <b>7.03A-B</b> Engine Parameters .....	page 14
Table <b>7.04</b> Alarms Options .....	page 15
Table <b>7.05</b> Miscellaneous .....	page 15
Table <b>7.06</b> Programmable Inputs .....	page 16
Table <b>7.07</b> Input Options list.....	page 16
Table <b>7.08</b> Programmable Outputs .....	page 16
Table <b>7.09</b> Outputs Options list .....	page 17
<b>8.0 Alarms, Warnings &amp; Shutdowns</b> .....	<b>page 18</b>
<b>9.0 Hour Meter</b> .....	<b>page 18</b>
<b>10.0 Be242; settings for Pump Set</b> .....	<b>page 18</b>
<b>11.0 Engine Running detect</b> .....	<b>page 19</b>
<b>12.0 Memory Clear</b> .....	<b>page 19</b>
<b>13.0 Troubleshooting guide</b> .....	<b>page 19</b>
<b>14.0 General Specifications</b> .....	<b>page 21</b>
<b>15.0 Software Upgrades &amp; Revisions</b> .....	<b>page 21</b>
<b>16.0 Application Notes</b> .....	<b>page 22</b>
<b>17.0 Interfacing with remote Auto start</b> .....	<b>page 22</b>
<b>18.0 Typical application wiring</b> .....	<b>page 23,24</b>
<b>19.0 Dimensions &amp; Connections</b> .....	<b>page 25</b>

**Section 1.0 BE242 controller introduction**

The Be242 controller is a 3-Phase utility power monitoring system that integrates a generator controller. The Be242 provides visual indication by means of LEDs and Displays for Engine & Electrical parameters, Alarms and Status of the contactors. Figure 1 presents the panel layout. The Be242 is connected to the Be242RB (Relay Board) via a 25 poles shielded cable supplied in the BE242 KIT box. The BE242 complies with NFP110 CAN/CSA-C282-M89 regulations.

Figure 1: BE242 controller Front Panel layout

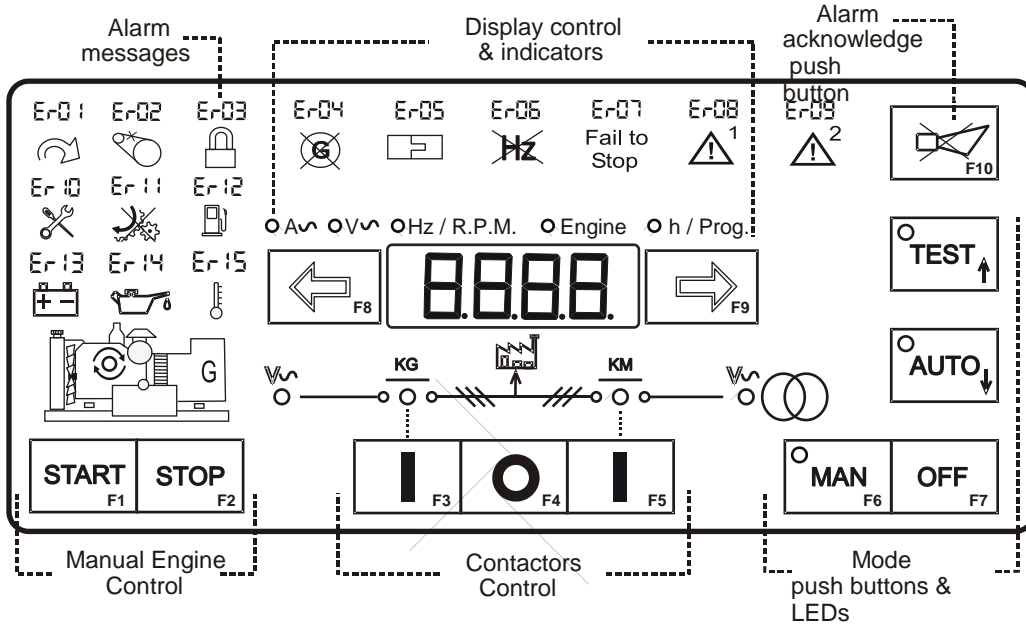

**Section 2.0: Selection of the Mode of operation**

When you apply the DC supply, the display indicates for a second, the version of the software (example 1.0.01) and the detected kind of battery (12V or 24V) Should the battery supply be lower than 7,5V, the BE242 will trigger the [ER.13] alarm code; the software will not run. The modes of operation are selected by push buttons and indicated by means of green LED indicators as shown below:

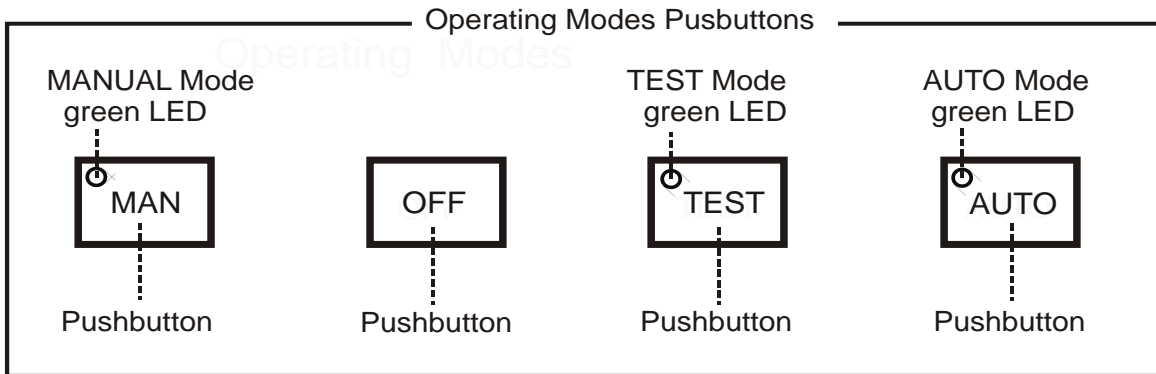

**Note: default programming for emergency input is 'normally closed'. To inhibit the alarm [Er.08] you are required to connect terminal JH4 to JH1 (Emergency input) on the back of the controller. You can reverse the contact by changing the type of the contact (see P35 on table 7.04).**

Every time the power supply is switched on, if the BE242 was in TEST or AUTO prior to power down, the Be242 returns to the "AUTO" mode. In the other cases, the Be242 will enter the OFF mode. The following table indicates the modes of operation.

Mode	Push button	Indication	Section
OFF	[ OFF ]	All turned Off, dot on the display	2.1
MANUAL	[ MAN ]	thr freen LED on the button	2.2
AUTO	[AUTO]	the green LED on the button	2.3
TEST	[TEST]	the green LED on the button	2.4
PROGRAMMING	see section 6.0 and 13.0	The display shows <b>[ProG]</b>	6.0
TROUBLESHOOTING		Various messages	13.0

**2.1 BE242 CONTROLLER OFF mode**

Push the button [OFF] to enter the OFF mode. The OFF mode clears the fault alarms and allows you to read or program parameters (section 6.0). The Display and LEDs are turned off and a dot on the display will blink slowly. Push one of the push buttons on the front panel to activate the display.

**2.2 BE242 CONTROLLER MANUAL mode**

**Note: default programming for emergency input is 'normally closed '. To inhibit the alarm [Er.08] you are required to connect terminal JH4 to JH1 (Emergency input). You can reverse the contact by changing the type of the contact (see P35 on table 7.04).**

The MANUAL mode allows manual control of the Engine and Contactors.

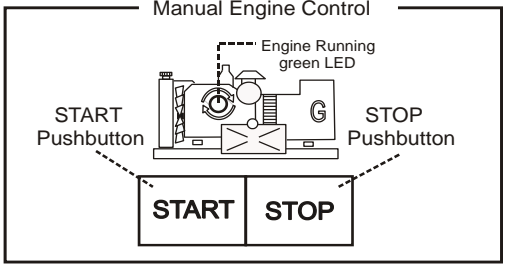
Manual Engine Control	Instructions
 <p>The diagram shows a control panel with two pushbuttons labeled 'START' and 'STOP'. Above the buttons is a green LED labeled 'Engine Running green LED'. Dashed lines connect the 'START' button to the 'START' pushbutton label and the 'STOP' button to the 'STOP' pushbutton label. A 'G' symbol is also visible on the panel.</p>	<p>Push the [MAN] push button to select the MANUAL mode. Push the [START] push button until the engine starts; the display indicates the message [. . .] during the starting attempts (and [! !] during the preheat). When the engine is running, the green LED turns on. To stop the engine, push the [STOP] push button until the [StOP] message appears on the display. If the engine has already stopped, it is possible to reset the STOP sequence by pressing the [STOP] push button.</p>

**2.21 Contactors: BE242 CONTROLLER Manual control** follow the instructions:

	<p style="text-align: center;">Instructions</p> <p>Select the MANUAL mode, start the engine (see above) and wait for voltage presence. Push the [ I ] (KG) push button to close the Load to Mains, push the [I] (KM) push button (the [KG] will open). To open a Contactor, push the [O] push button. In manual mode the CHANGEOVER timer lasts one second. The green indicators of voltage (Mains or Generator) blink when the voltage or frequency is out of limit (see the Mains and Generator parameters in table 7.01-7.02). The indicators are off when the voltage is lower than 48Vac</p>
--	---

**2.3 BE242 CONTROLLER AUTO mode**

Push the [AUTO] push button until the green LED illuminates. The engine starts when the Be242 detects a Mains failure (see Table 7.01A). The Contactor of the MAINS (KM) opens after the BREAKER timing. After the warm-up time, if the Voltage and Frequency are within the settings, the contactor of the Generator (KG) will close. If the Mains restores, the KG will open. The KM will close following a programmed changeover timing. The Engine will stop after a cooling down time (see tables 7.02 and 7.03). If the engine shuts down, the KM closes independently of the Mains status if the [P.48] is [ON] (NFPA-110 mode), otherwise, the KM will close only if the Mains is within programmed settings. In AUTO mode, the Be242 will periodically test the engine if the parameters [P.41] and [P.42] have been programmed. During this test, the green LED of the AUTO mode will continue to blink. In AUTO mode, the Be242 can start and stop the engine according to programmed inputs (see Tables 7.06 and 7.07 options [10] & [11] for example).

Note: when the Mains (or Generator) is in stable condition, the green LED 'V' is permanently ON. When voltage or frequency is outside limits, the green indicator 'V' blinks slowly (see table 7.01-7.02).

**2.4 BE242 CONTROLLER TEST mode**

Push the [TEST] push button until the green LED illuminates. The Be242 starts the engine and transfers the load to the Generator if [P.17] is [on]. To stop the engine, select the AUTO mode (if Mains is present) or select the OFF mode. If you push the [STOP] push button when the Be242 is in AUTO or TEST, the [Er.09] will energize. To clear the alarm, select the OFF mode (section 8.0).

**2.5 BE242 CONTROLLER PROGRAM mode**

The PROGRAM mode allows parameter programming and modifications of settings. A password can be set to protect the panel from unauthorized access (see 6.0).

**2.6 BE242 CONTROLLER TROUBLESHOOTING mode**

The TROUBLESHOOTING mode is used to diagnose system faults (see 13.0).

**Section 3.0 BE242 CONTROLLER Display measurements**

The Be242 features a 4 Digit display, two push buttons and 5 yellow LEDs as indicated below.

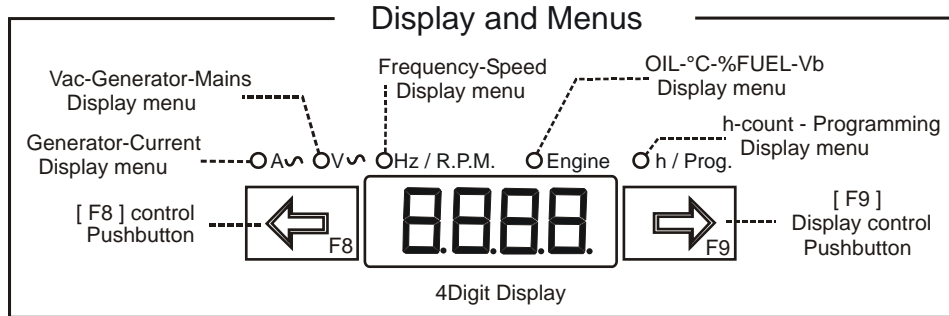

Use [←F8] and [F9→] to select a menu. Use [ACK-F10] (see the layout in section 1.0) to display the name of the parameter. The OFF mode of operation shuts down the display and turns on the dot on the right side of it. Push a button to turn on the panel. The following table includes the functions of the display.

Display Function	Display indications (*)	Push button(s)	
The Current of the Generator or Utility Power (0 up to 1000A)	[A XXX] Ampere L1 [- XXX] Ampere L2 [_ XXX] Ampere L3	[←F8] or [F9→]	A ac menu yellow indicator
	[A -G]	[ACK-F10]	
The Voltage of the Generator (60V up to 998V)	[G XXX] Volt L1-L2 [- XXX] Volt L2-L3 [_ XXX] Volt L1-L3	[←F8] or [F9→]	V ac menu yellow indicator
	[U -G]	[ACK-F10]	
The Voltage of the Mains (60 V up to 998 V). If the Mains is simulated, the display will show the message [n-on]	[n XXX] (V R-S) [- XXX] (V S-T) [_ XXX] (L R-T)	[←F8] or [F9→]	
	[U -on]	[ACK-F10]	
The Generator Frequency (20Hz up to 70Hz)	[G XXX] Hz	[←F8] or [F9→]	Hz/RPM menu yellow indicator
	[H - G]	[ACK-F10]	
The Mains Frequency (20Hz up to 70Hz)	[n XXX] Hz	[←F8] or [F9→]	
	[H - n]	[ACK-F10]	
The Speed indication (600RPM up to 4000RPM)	[XXXX] RPM	[←F8] or [F9→]	Hz/RPM menu yellow indicator
	[SPd]	[ACK-F10]	
Battery Voltage (5.5 Vdc up to 36 Vdc)	[b XX.X] Vdc	[←F8] or [F9→]	Engine yellow indicator
	[batt]	[ACK-F10]	
Charger Voltage (3.0 Vdc up to 36 Vdc)	[c XX.X] Vdc	[←F8] or [F9→]	
The Hours-count: 0 up to 50,000 h.	[XXXX] h	[←F8] or [F9→]	h/Prog menu yellow indicator
	[Hour]	[ACK-F10]	

(\*)NOTE: X indicates a numerical digit, if the measurement is out of range, the display will indicate [- - -]

**Section 4.0 BE242 CONTROLLER Display messages and LOG Events**

The Be242 displays alarms (table 4.10) and messages (table 4.20). The presence of alarms is indicated by the blinking message [ALAr.]. Push the [→F9] push buttons to display the alarms one by one. Push the [←F8] push button to display additional information (section 8.0).

**Table 4.10: Alarm messages**

Display Message	Description of the Alarm	Display Message	Description of the Alarm
[Er.01]	Over Frequency Shutdown (see [P.12])	[Er. 14]	Low Oil Pressure Shutdown (Pressure switch connected to input #35)
[Er.02]	Engine Belt Break Shutdown (see [P.26])	[Er. 15]	Temperature Switch Shutdown (Temperature switch connected to Input #34)
[Er.03]	Remote LOCK Shutdown (see 7.07 option [13])	[Hi-C]	Over Current Shutdown or Warning (see [P.13]).
[Er.04]	Alternator Failure Shutdown	[Hi-U]	Over Voltage Shutdown (see [P.10])
[Er.05]	Overload Warning (see 7.07 option [20])	[Lo-U]	Under Voltage Shutdown (see [P.09])
[Er.05]	Overload Shutdown (see 7.07 option [21])	[InP.2]	Input 2 Shutdown / Warning (see 7.07)
[Er.06]	Under Frequency Shutdown (see [P.11])		
[Er.07]	Fail To STOP Shutdown (see parameter P.34, section 7, table 7.04)	[InP.3]	Input 3 Shutdown / Warning (see 7.07)
[Er.08]	Emergency Shutdown (see parameter P.35, section 7, table 7.04)	[InP.4]	Input 4 Shutdown / Warning (see 7.07)
[Er.09]	Emergency Shutdown triggered by Front Panel (Stop or [0] push button)	[FUEL]	Low Fuel level warning
[Er.10]	Maintenance SERVICE warning (see parameters P44,P45 and P46)	[rEnt]	The rental contract is going to expire (48 hours remaining). Push [←F8] to display the value.
[Er.11]	Fail To START Shutdown	[FAIL]	There is an internal failure or memory error in the BE242 controller (see 12.3)
[Er.12]	Low Fuel Shutdown	[Er. 13]	Battery Voltage Alarm. Push [←F8] to display the value. (allowed battery limits: 11,8V-15,5V & 23,6V-31V). Under 7,5V, the Be242 controller will not work.

**4.20 Miscellaneous messages & description**

[rESt]	The Be242 is counting the rest time between the starting attempts	[ProG]	The Be242 is in program mode
[n-on]	The MAINS is simulated by an input programmed with the option [15] (see table 7.07).	[. . . .]	The Be242 is cranking the engine
[ ' ' ' ' ]	The Be242 is performing the pre-glow (P22)	[tEst]	The Be242 is in Test mode
[StoP]	The Be242 is stopping the engine (P25)	[ - - - - ]	Measurement out of range or disabled
[U-uP]	Warm-up time of the engine before closing the contactor of the generator (P23).	[Cool]	The engine is running offload for cooling.
[ dEL]	The delay time before cranking (P.19, table 7.03A)		



### **4.30 BE242 CONTROLLER LOG EVENTS**

To have access to the LOG events follow the instructions:

- Push the [OFF] button.
- Push and hold the [STOP] button until the message [Hist.] appears on display (approx. 10 seconds).
- Release the [STOP] button.
- Using [←F8] and [F9→] you can browse the events E01 up to E100.
- Push the [STOP] button to display the code of the EVENT (see table 4.10). The message [---] indicates 'No Event' in the memory.
- To quit the LOG EVENTS push the [OFF] button.

Note: to cancel the LOG EVENTS push the [←F8] and [F9→] buttons simultaneously until the display blinks one time (approx. 10 seconds).

## **Section 5.0 LED indicators**

### **5.1 Lamp and Display Testing**

To test the LEDs and DISPLAY push the [OFF] push button; the display turns off (OFF mode of operation). Push and hold the [←F8] and [F9→] push buttons simultaneously. The LEDs and DISPLAYs remain energized as long as the push buttons are pressed and held together.

## **Section 6.0 Programming / Reading the Parameters**

The 4-digits display indicates the code of a parameter and its setting. Section 7.0 lists all parameters. To enter the Programming Mode, use the following instructions. To use a password see sections 6.40, 6.50 and 6.60. Monitoring via TCP-IP is also allowed.

### **6.10 Enter the Programming Mode**

- 1) - Provide a voltage from a battery supply of *over 11.5 V*. Push the [OFF-F7] push button to enter the OFF mode; the LEDs and display turn OFF (the dot on the right side of the display will start to blink)
- 2) - Push and hold the [F9→] and [ACK-F10] push buttons simultaneously for about 5 seconds, until the yellow Led [h/Prog.] starts to blink. When the display indicates [ProG], release the buttons.
- 3) - If the Be242 is ***password protected*** (\*), the messages [PASS] and [42.42] will appear in sequence; you are required to follow the instructions of Table 6.11. If the Be242 is ***not password protected***, the programmable parameter [P.0] will be displayed and the Be242 is ready for programming (section 6.12, step-2).

**(\*) Note: the password consists of 2 groups of digits ranging from 0 to 99. Example: [12.34]; 12 is the 2-digit code on the left, and 34 is the 2-digit code on the right.**

**TABLE 6.11: Enter the PASSWORD**

- 1) - Push [TEST] or [AUTO] in order to choose the proper code (between 00 and 99, except 42).
- 2) - Push [F9→] to select the 2 digits on the right side.
- 3) - Push [TEST] or [AUTO] in order to choose the proper code (between 00 and 99, except 42).
- 4) - Push [ACK-F10] to confirm the password; if the password is ok, the Be242 will indicate [P.0] and the unit is ready for programming. If the password is wrong, the display will indicate [4242] and you are required to insert the correct password.

*If you lose the password, the unit must be returned for service.*

### **6.12 Programming**

- 1)** - Enter the Programming mode (see section 6.10).
- 2)** - Press the [←F8] or [F9→] push button to select a parameter (see the list in section 7.0).
- 3)** - To adjust the parameter, press [START-F1] and [TEST ↑] (or [AUTO ↓]) simultaneously.  
(example: [P.10] = [500]; the Overvoltage limit is set to 500 Volt. If you want to set 450, push and hold [START-F1] and [AUTO ↓] until the display indicates 450 )
- 4)** - To adjust additional features of the same parameter, press [STOP-F2] and [TEST ↑] (or [AUTO ↓]) simultaneously (example: [P.10] [10"]; the timing delay of Overvoltage is set to 10 seconds)
- 5)** - Press the [←F8] or [F9→] push button to select another parameter.
- 6)** - Follow the instructions of sections 6.13 or 6.14 according to your needs.

### **6.13 Saving**

Press and hold the [ACK-F10] and [F9→] push buttons simultaneously until the [SaVE] message appears (approximately 5 seconds); the Be242 saves the settings and will enter the OFF mode. You can select the mode of operation as indicated in section 2.0.

**Note: if the memory fails, the message [FAIL] will appear. Try again to save or remove the power supply. If the message persists, the Be242 is damaged and should be returned to Bernini Design for repair.**

### **6.14 Exit without Saving**

Press the [OFF] push button to enter the OFF mode without saving the parameters. You can select a mode of operation as indicated in section 2.0.

### **6.20 Re-programming Default settings**

The parameters of the Be242 are programmed in the factory with default settings (section 7.0). To restore them, enter the Programming Mode (section 6.10). When the message [P.0] appears, follow the instructions:

- 1)** - Press and hold the [←F8] and [F9→] push buttons simultaneously until the display blinks twice. Select options 2A or 2B according to your needs.
- 2A)** - Press the [OFF] push button to exit the procedure without saving the parameters.
- 2B)** - Press and hold the [ACK-F10] and [F9→] push buttons simultaneously until the [SAVE] message appears (approximately 5 seconds); the Be242 saves the settings and the display will indicate [P0]. Push the [OFF] push button in order to enter the OFF mode.

### **6.30 Reading the parameters**

To read the parameter settings, follow the instructions:

- 1)** - Press the [OFF] push button until the LEDs and display turn off (OFF mode of operation).
- 2)** - Push the [←F8] or [F9→] push button to select a parameter (section 7.0).
- 3)** - Push [START-F1] to display the setting of the parameter (example: [P.10] > [450]; the Overvoltage limit is set to 450 Volt).
- 4)** - Push [STOP-F2] to display the setting of the sub-parameter (example: [P.10] > [2"]. The timing delay of Overvoltage is set to 2 seconds).
- 5)** - Push the [←F8] or [F9→] push button to select another parameter.

**NOTE: if the push buttons remain inoperative for more than 5 minutes, the Be242 enters the OFF mode.**

### **6.40 Activating the password**

- 1) - Enter the programming mode as indicated in section 6.10.
- 2) - When the display shows [P.0], push the [ACK-F10] push button for about 10 seconds until the display shows [PPPP]. When the display will indicate [4242], release the button. The two digits on the right will blink.
- 3) - Push [TEST] or [AUTO] in order to choose a code.
- 4) - Push [←F8] to select the 2 digits on the left side. Repeat step 3) in order to choose a code
- 5) - Press the [OFF] push button if you want to exit the procedure without activating the password.
- 6) - Press and hold the [ACK-F10] and [F9→] push buttons simultaneously until the [SAVE] message appears; the Be242 saves the password and remains in PROGRAM mode. To exit, push the OFF push button. You can change the password at any time as indicated in section 6.50.

### **6.50 Changing the password**

- 1) - Enter the programming as indicated in section 6.10 and table 6.11. When the display indicates the parameter [P.0], push and hold the [ACK-F10] push button for about 10 seconds until the messages [PP.PP] and [4242] appear. The two digits on the right side of the display will blink.
- 2) - Push [TEST] or [AUTO] in order to choose a code.
- 3) - Push [←F8] to select the 2 digits on the left side. Repeat step 3) in order to choose a code
- 4) - Press the [OFF] push button if you want to exit the procedure without activating the password.
- 5) - Press and hold the [ACK-F10] and [F9→] push buttons simultaneously until the [SAVE] message appears (approximately 5 seconds); the Be242 saves the password and remains in PROGRAM mode. To exit, push the OFF push button.

### **6.60 Removing the password**

- 1) - Enter the programming mode as indicated in section 6.10 part 3 (you are required to use the old password).
- 2) - When the display indicates the parameter [P.0], push and hold the [ACK-F10] push button, for about 10 seconds until the display indicates in sequence [PPPP] and [4242]. The two digits on the right side will start to blink. The code [4242] disables the use of the password. Follow step 3 of 4 according to your needs.
- 3) - Press the [OFF] push button if you no longer want to remove the password (exits the procedure).
- 4) - Press and hold the [ACK-F10] and [F9→] push buttons simultaneously until the [SAVE] message appears (approximately 5 seconds); the Be242 saves the code [4242] that disables the password. The Be242 remains in PROGRAM mode. To exit, push the OFF push button.

### **6.70 Losing the password**

**In case you lose the password follow the steps:**

- remove the supply
- push and hold the [ACK] and [>] push buttons
- apply the supply; a 4-digit code appears on the display
- send the code to [bernini@bernini-design.com](mailto:bernini@bernini-design.com) together with your credentials.
- you will receive the new password in 24 hours.

## **Section 7.0 ADJUSTABLE PARAMETERS LIST**

The programmable parameters are divided into classes as indicated below.

- |                                     |                             |
|-------------------------------------|-----------------------------|
| 7.01 - A, B - Mains Failure Control | 7.07 - Input Options List   |
| 7.02 - A, B - Generator Parameters  | 7.08 - Programmable Outputs |
| 7.03 - A, B - Engine Parameters     | 7.09 - Output Options table |
| 7.04 - Alarms Options               |                             |
| 7.05 - Miscellaneous                |                             |
| 7.06 - Programmable Inputs          |                             |

<b>Table 7.01A - Mains Failure Control</b> Note: [ xx " ] = seconds, [ xx ' ] = minutes, [xxh ] = hours				
Parameter Code & Description		Default	Min	Max
P.0	Mains Contactor Control (KM). If the Mains Failure persists for more than [P.0] (seconds or minutes), the Mains contactor will open and the [P.1] timer will start to count. The Mains contactor will close only after the [P.2] timing.	[ 5'' ]	0	59 mins
P.1	Mains Failure time. After the [P.0] timing (see above), the engine will start if the Mains Failure persists for the [P.1] time.	[ 5'' ]	0	23 h
P.2	Mains Restore time. The Be242 transfers the Load to the Mains once the MAINS is stable for at least [P.2] (seconds, minutes or hours). During [P.2], the engine will continue to run ON-LOAD. After [P.2], the [P.24] timer will take place to run the engine OFF-LOAD (the contactor of the generator will open).	[ 5'' ]	0	23 h

**NOTE: WHEN VOLTAGE OR FREQUENCY IS OUTSIDE LIMITS, THE GREEN INDICATORS BLINK SLOWLY. DANGEROUS VOLTAGE MAY BE PRESENT IN THE CONTROLLER EVEN IN CASE THE INDICATORS ARE OFF**

<b>Table 7.01B - Mains Failure Control</b> Note: [ xx " ] = seconds, [ xx ' ] = minutes, [ oFF ] = disabled					
Parameter Code & Description		Default	Min	Max	Options
P.3	Contactors changeover. This timing introduces a delay between the switching of the contactors.	[ 2'' ]	0.1secs	15.0secs	-
P.4	Undervoltage limit. If the Phase-to-Phase voltage falls under this limit, the [P.0] timer will energize.	[320]	60V	998V	[oFF]
P.5	Overvoltage limit. If the Phase-to-Phase voltage rises above the limit, the [P.0] timer will energize.	[500]	60V	998V	[oFF]
P.6	UnderHz limit. If the Phase-to-Phase frequency falls under the limit, the [P.0] timer will energise.	[47.0]	20.0Hz	70.0Hz	[oFF]
P.7	OverHz limit. If the Phase-to-Phase frequency rises above the limit, the [P.0] timer will energise.	[53.0]	20.0Hz	70.0Hz	[oFF]
P.8	Phase Selection. It allows 3-Phase or Single Phase control of voltages and currents. The following options are available: [0] 3 Phase V Mains & 3 Phase Generator [1] 3 Phase V Mains & 1 Phase Generator [2] 1 Phase V Mains & 3 Phase Generator [3] 1 Phase V Mains & 1 Phase Generator	[0]	0	3	-

**Table 7.02A - GENERATOR PARAMETERS** Note: [ xx " ] = seconds, [ xx ' ] = minutes, [ oFF ] = disabled

Parameter Code & Description		Mode (°)	Default	Min	Max	Options
P.9	Under voltage (Push F1)	1	[320]	60 V	998 V	[oFF]
	Delay (Push F2)		[ 6" ]	1 sec	15 secs	-
P.10	Overvoltage (Push F1)	2	[500]	60 V	998 V	[oFF]
	Delay (Push F2)		[ 2" ]	1 sec	15 secs	-
P.11	Under Hz (Push F1)	1	[47.0]	20.0 Hz	70.0 Hz	[oFF]
	Delay (Push F2)		[ 6" ]	1 sec	15 secs	-
P.12	Over Hz (Push F1)	2	[53.0]	20.0 Hz	70.0 Hz	[oFF]
	Delay (Push F2)		[ 1" ]	1 sec	15 secs	-
P.13 (*)	Current limit Warning (Push F1)	3	[oFF]	10 A	999 A	[oFF]
	Delay (Push F2)		[ 1" ]	1 sec	15 mins	-
P.14 (*)	Over-current shutdown (Push F1)	1	[oFF]	10 A	999 A	[oFF]
	Delay (Push F2)		[ 1" ]	1 sec	15 mins	-

(°) Mode 1: The engine shuts down after cooling down time ([P.24]). (°) Mode2: The engine shuts down without cooling down time.  
 (°) Mode 3: The Be242 provides a warning if the parameters rise above the setting for the specified timing.  
 (\*) The setting is allowed in step 5 Amps by using the push button on Be242 or in the step of 1Amp by using programming by Computer.

**NOTE: WHEN VOLTAGE OR FREQUENCY IS OUTSIDE LIMITS, THE GREEN INDICATORS BLINK SLOWLY. VOLTAGE MAY BE PRESENT IN THE CONTROLLER EVEN IN CASE THE INDICATORS ARE OFF**

**Table 7.02B - GENERATOR PARAMETERS**

Note: [ oFF ] = disabled, [ on ] = enabled

Parameter Code & Description		Default	Min	Max	Options
P.15	Alternator failure options. The alarm [E04] energizes if the voltage (or the frequency) is lower than the setting of P.9 (or P11) for more than 150 seconds.	[oFF]	-	-	[on] [oFF]
P.16	Alternator number of Poles. Options [2] or [4] allow you to display the engine speed.	[ 4 ]	2	4	-
P.17	Generator Contactor Control. The option [off] inhibits Load transfer to the generator in TEST mode (or remote TEST) when MAINS is present.	[oFF]	-	-	[on] [oFF]
P.18	CT size (/5Aac).	[100]	50 A	1000 A	-

<b>Table 7.03A - ENGINE PARAMETERS</b> Note: [ xx " ] = seconds, [ xx ' ] = minutes, [ oFF ] = disabled					
<b>Parameter Code &amp; Description</b>		<b>Default</b>	<b>Min</b>	<b>Max</b>	<b>Options</b>
P.19	Crank delay (it delays the cranking)	[ 2" ]	0	15 secs	-
P.20	Crank time (maximum cranking time if the engine fails to start during the attempt)	[ 5" ]	1 sec	15 secs	-
P.21	Rest time (pause of time between starting attempts)	[ 5" ]	3 secs	15 secs	-
P.22	Pre-glow time (see 'Modes' for the mode of operation. (Push F1)	[ oFF ]	1 sec	59 mins	[ oFF ]
	Modes as indicated below (Push F2)	[ 1 ]	-	-	1-2-3-4
<p>The diagram illustrates the timing sequence for engine starting. It shows five horizontal bars representing different states over time. From top to bottom: 'Starting Motor' (a pulse), 'Pre-glow mode 1' (a pulse), 'Pre-glow mode 2' (a pulse), 'Pre-glow mode 3' (a pulse), and 'Pre-glow mode 4 (Choke)' (a pulse). A 'Total rest timing' bar is shown as a gap between the end of the pre-glow pulses and the start of the next. A 'Crank termination (engine running detect)' bar is shown as a pulse that occurs after the pre-glow pulses. Arrows indicate the duration of the pre-glow pulses is controlled by P.22, the rest timing by P.21, and the crank termination by P.26, P.27, and P.28. A vertical dashed line marks the end of the pre-glow period.</p>					
P.23	Engine Warm-up time	[ 15" ]	0	59 mins	-
P.24	Engine Cooling time	[ 15" ]	0	59 mins	-
P.25	Stop Solenoid timing (Energized to stop)	[ 5" ]	1 sec	59 mins	-
P.26	Alternator Crank termination (Push F1)	[ oFF ]	3.0 V	30.0 V	[oFF]
	Belt break setting (Push F2)	[ oFF ]	3.0 V	30.0 V	[oFF]
P.27	Crank termination setting (Generator Voltage)	[ 100 ]	60 V	998 V	[oFF]
P.28	Crank termination (Generator Frequency)	[30.0]	20.0 Hz	70.0 Hz	[oFF]

<b>Table 7.03B - ENGINE PARAMETERS</b> Note: [ xx " ] = seconds, [ xx ' ] = minutes, [ oFF ] = disabled					
<b>Parameter Code &amp; Description</b>		<b>Default</b>	<b>Min</b>	<b>Max</b>	<b>Options</b>
29-30	NOT USED	[ oFF ]			
P.31	Crank attempts (numbers)	[ 3 ]	3	15	-
P.32	Purge timing (for Gas fuelled engine)	[ 1" ]	1 sec	15 secs	-

<b>Table 7.04 - ALARM OPTIONS</b> Note: [ xx " ] = seconds, [ xx ' ] = minutes, [ oFF ] = disabled					
<b>Parameter Code &amp; Description</b>		<b>Default</b>	<b>Min</b>	<b>Max</b>	<b>Options</b>
P.33	Alarm bypass (for Oil, Temperature, Auxiliary 2-3-4 alarms)	[ 5" ]	2 secs	90 secs	-
P.34	Fail to stop alarm control (oFF = inhibited, on = enabled)	[oFF]	-	-	[oFF]/ [on]
P.35	Emergency contact type (Input JH1-JH4). It generates the alarm [Er.08].	[n.c.]	-	-	[n.o. / n.c.]
P.36	No fuel bypass timeout (it starts to count when you activate the Low Fuel Input, terminal #9. <b>It shuts down the engine after timeout</b> ).	[ 5' ]	15 secs	99 mins	[oFF]
P.37.38	NOT USED	[ oFF ]			
P.39	Engine Temperature Switch type (input # 12)	[n.o.]	-	-	[n.o. / n.c.]

<b>Table 7.05 - MISCELLANEOUS</b> Note: [ xx " ] = seconds, [ xx ' ] = minutes, [ oFF ] = disabled					
<b>Parameter Code &amp; Description</b>		<b>Default</b>	<b>Min</b>	<b>Max</b>	<b>Options</b>
P.40	EJP time	[ 5" ]	1 sec	99 mins	-
P.41	Periodic Test interval (see 16.10)	[oFF]	2 hours	9999 h	[oFF]
P.42	Periodic Test duration (see 16.10)	[ 5' ]	1 min	99 mins	-
P.43	Test timeout ([OFF]= no timeout). It limits the running time in case of a TEST initiated by a MODBUS command. Idle speed control (see application note in section 16.60)	[ 5' ]	1 min	99 mins	[oFF]
Ser.1 Ser.2 Ser.3	Maintenance SERVICE 1 / 2 / 3 (for the use, see section 16.40) The alarm generated by these parameters only provides a warning.	[oFF]	1 h	9999 h	[oFF]
P.47	Rental Contract Setting (see section 16.40)	[oFF]	1 h	9999 h	[oFF]
P.48	NFPA - 110 Level 1&2	[on]	-	-	[on]/[oFF]
P.49	NOT USED	[ 1 ]			
P.50	Horn timeout (see section 8.0)	[ 5" ]	5secs	15 mins	[oFF]
P.51	Hour Counter set (over 9999, a dot will appear to indicate a value multiplied by 10. Example 3250. will indicate 32500 hours. In this case the resolution is 10 hours).	[ 0 ]	0 h	50.000	[oFF]

**Table 7.06 - Programmable inputs (see options list in table 7.07)**

Parameter		Options	Default	Parameter		Options	Default
<b>[InP.1]</b> NOT USED		NONE	[ 2 ]	<b>[InP.3]</b> (terminal #10 on B242RB)	Option available	[0] - - - [28]	[10]
					Contact type	[n.o.][n.c.]	[n.o.]
<b>[InP.2]</b> (terminal #13 on B242RB)	[ 13 ]	[0] - - - [28]	[13]	<b>[InP.4]</b> (terminal #14 on B242RB)	Option available	[0] - - - [28]	[15]
	Contac_t type	[n.o.][n.c.]	[n.o.]		Contact type	[n.o. ][n.c.]	[n.o.]

**Table 7.07 - Input Options List**

Option		Option	
[ 0 ]	Off: disables the input	[ 14 ]	Generator simulation ON
[ 1 ]	Immediate Stop	[ 15 ]	Mains Simulated ON
[ 2 ]	Bypass and Stop	[ 16 ]	Front panel LEDs test
[ 3 ]	Cooling and Stop	[ 17 ]	Horn silence
[ 4 ]	Bypass+Cooling and Stop	[ 18 ]	Display Right Push button
[ 5 ]	Warning only (^)	[ 19 ]	Display Left Push button
[ 6 ]	Bypass and Warning	[ 20 ]	Overload Input Warning
[ 7 ]	Remote Manual Mode (^^)	[ 21 ]	Overload Input Shutdown
[ 8 ]	Remote Auto Mode (^^)	[ 22 ]	KG Forced closed
[ 9 ]	Remote Off Mode (^^)	[ 23 ]	KM Forced closed
[ 10 ]	Remote Engine Test	[ 24 ]	KG LED Feedback
[ 11 ]	Remote Generator Test	[ 25 ]	KM LED Feedback
[ 12 ]	Ejp function	[ 26 ]	Idle Engine
[ 13 ]	Remote LOCK	[ 27 ]	Manual START push button
		[ 28 ]	Manual STOP push button

(^) The Be242 detects the alarm if the engine is running

(^^) We recommend the use of an AUTO-OFF-MAN switch

**7.08 - Programmable Outputs**

Parameter Code & description		Default	Parameter Code & description		Default	Options
[Out.1]	Output 1 (terminal #6 HORN)	[ 39 ]	[Out.3]	NOT USED [ 54 ]		
[Out.2]	Output 2 (terminal #5 PREGLOW)	[ 46 ]	[Out.4]	NOT USED [ 57 ]		



Table 7.09 - Output Options Table

Option & description		Option & description	
[ 0 ]	Output is disabled	[32]	Alarm from Input 2: Shutdown/Warning
[ 1 ]	Under Frequency Shutdown	[33]	Alarm from Input 3: Shutdown/Warning
[ 2 ]	Over Frequency Shutdown	[34]	Alarm from Input 4: Shutdown/Warning
[ 3 ]	Over Current Shutdown	[35]	NOT USED
[ 4 ]	Over Current Warning	[36]	NOT USED
[ 5 ]	Overload Warning or Shutdown (^^^)	[37]	Cumulative Alternator Alarms
[ 6 ]	Over Voltage Shutdown	[38]	Common Fuel Alarms
[ 7 ]	Under Voltage Shutdown	[39]	HORN
[ 8 ]	Alternator Failure Shutdown	[40]	Crank Delay (Start Warning)
[ 9 ]	NOT USED	[41]	Presence of Nominal Mains Parameters
[10]	Low Oil Pressure Shutdown	[42]	Mains Failure Timing
[11]	NOT USED	[43]	Mains Restore Timing
[12]	NOT USED	[44]	KG Status
[13]	Temperature Switch Shutdown	[45]	KM Status
[14]	NOT USED	[46]	Pre-glow MODE 1/2/3/4
[15]	Low Battery Voltage Warning	[47]	NOT USED
[16]	High Battery Voltage Warning	[48]	RENT<48h
[17]	Low Fuel Shutdown (switch)	[49]	RENT=0h (Expired)
[18]	NOT USED	[50]	Engine Running Status
[19]	Fuel Reserve Warning (switch)	[51]	Presence of Nominal Generator Voltage
[20]	NOT USED	[52]	Be242 in OFF MODE (Status)
[21]	NOT USED	[53]	Be242 in MANUAL MODE (Status)
[22]	Emergency Stop Shutdown (Er08)	[54]	Be242 in AUTO MODE (Status)
[23]	Stop Push button Used in AUTO (Er09)	[55]	Be242 in TEST MODE (Status)
[24]	Maintenance SERVICE 1 (Er10)	[56]	Be242 in LOCK MODE (Status)
[25]	Maintenance SERVICE 2 (Er10)	[57]	Be242 runs the Automatic Periodic Test
[26]	Maintenance SERVICE 3 (Er10)	[58]	Cooling Timing
[27]	Engine Belt Break Shutdown	[59]	Warm-up Timing
[28]	Fail To START Shutdown	[60]	Cycling mode (Logical OR of engine running and stop solenoid)
[29]	Fail To STOP Shutdown	[61]	Start Pilot repeat output (it repeats the crank output terminal #9)
[30]	Idle Speed (see section 16.60)	-	--
[31]	NOT USED	-	--

## **Section 8.0 - Alarms, Warnings and Shutdowns**

The Be242 features Shutdowns (the engine stops) and Warnings (the engine will continue to run) and provides:

- A)** - a general indication of alarm presence by means of the message [ALAr.] on the display
- B)** - 2 configurable outputs for specific alarm indications with more than 40 options (see 7.08 and 7.09)
- C)** - symbols on the front panel to indicate the most important alarms
- D)** - display messages indicating warnings and shutdowns (see Table 4.1)
- E)** - a push button to silence the Horn ([ACK-F10])

Terminal #6 is pre-configured for HORN output (Option 39). A HORN should be externally provided. To silence the HORN, push the [ACK-F10] push button or wait for the **[P.50]** to expire (see section 7.05). If the **[P.50]** is set to **[OFF]**, the only way to silence the Horn is by means of the [ACK-F10] push button.

To browse the alarm memory push the [→F9] push button. To display alarm details, push the [←F8] push button. To clear the alarm from the panel, remove the cause of the alarm and then press the [OFF] push button. Table 4.10 in section 4.0 indicates all alarms.

## **Section 9.0 Hour Meter**

To clear or pre-load the counter, use the following instructions:

- 1)** - Enter the programming mode as indicated in sections 6.10 & 6.20
- 2)** - Select the parameter [P.51] by means of the [←F8] or [F9→] push button.
- 3)** - Press the [START-F1] and [TEST ↑] to set a value. If you set [0], you will cancel the [h-counter]. If you set a value between 1 and 50000, you will pre-set the counter. Follow steps 4A) or 4B) according to your needs.
- 4A)** - Press and hold the [ACK-F10] and [F9→] push buttons simultaneously until the [SaVE] message appears (for about 5 seconds); the Be242 saves the hour counter in the memory and will enter the OFF mode.
- 4B)** - Press the [OFF] push button to exit the procedure without modifying the counter.

## **Section 10.0 Be242 setting required for PUMP SET application**

If you use the Be242 to control a PUMP SET, we recommend the use of the following settings:

Parameter	Table 10.0: Recommended settings setup
[P.15]	<b>[oFF]</b> (This disables the 'alternator failure alarm')
[Inp.4]	<b>[ 15 ]</b> (This selects the Mains Simulation input mode). Connect a switch (or level switch) to terminal #14 in order to control the set by remote
[P.41]	<b>[oFF]</b> (This disables the Periodic Test interval)
[P.0]	<b>[ 0 ]</b> (This disables the Breaker delay time)
[P.1]	According to your needs; the engine will start after a delay
[P.2]	According to your needs; the engine will stop after a delay

## **Section 11.0 Engine Running Detect (Charger Alternator)**

The Be242 inhibits the starter motor when the engine starts running. When the engine is not running, the voltage in terminal D+/WL of the charger alternator (input #15) is 0 V. As soon as the Be242 starts the engine, a voltage appears in the D+/WL terminal (0.8 to 2.5 V). When the engine starts running, the voltage of the D+/WL terminal increases by up to 3 V - 6 V. When the engine runs, the voltage reaches 14 V (28 V) needed to charge the battery. The safest point to disconnect the starter motor is between 6 V to 10 V. The default parameter of [P.26] is 8.0 V. This value is recommended for engines using 12 V batteries. For 24 V batteries, we recommend that you set the threshold to 16 V.

For safe calibration, ensure the green 'ENGINE RUNNING' LED on the front panel is off during all of the starting attempts. The Charger Alternator voltage can be displayed in the 'Engine menu' as indicated in section 3.0. For Flywheel chargers, the reading is not accurate. The [P.26] setting, in this case, expresses only a proportional factor.

The Be242 also uses the output of the Generator in order to disconnect the crank motor. Parameters [P.27] and [P.28] set the crank termination. These parameters do not affect the status of the green 'ENGINE RUNNING' LED.

**NOTE: THE 'ENGINE RUNNING' LED MUST BE LIT WHEN THE ENGINE RUNS. USING THE ENGINE WITHOUT THIS SIGNAL MAY BE DANGEROUS.**

Normally, using a diesel engine, we recommend enabling the BELT BREAK protection. This is accomplished by programming a voltage setting in the [P.26] sub-menu. To test the efficiency of this protection, disconnect terminal D+ from the charger alternator and connect to ground the #15 terminal. This protection is delayed by 15 seconds.

## **Section 12.0 - Memory Reset**

### **12.3 - To clear the Memory**

- Remove the supply. Push and hold the [I-F3] & [I-F5] push buttons simultaneously and apply the Vdc supply.
- As soon as the message AUTO-TEST appears, release the push buttons; the display will indicate [ F1].
- Push [F1] and then push, one by one, all push buttons indicated by the message on display.
- After pushing the last push button ([AUTO]), the message [-EPP] will appear; wait a few seconds.
- The memory, now, is erased. The Be242 will use the factory-programmed parameters (defaults).
- Remove the supply and re-program the controller according to your need. We always recommend that you program a password in order to limit access (see section 6.40).

## **Section 13.0 Troubleshooting Guide**

The Basic Troubleshooting Guide is intended to provide you with a guide to problems that you may experience with the Be242. We recommend that you disconnect all removable terminal blocks from the BE242RB interface board. This procedure should only be carried out by qualified personnel.

**To exit the Troubleshooting, remove the Vdc supply at anytime**

**! WARNING !** High voltage is inside the Be242. To avoid electric-shock hazards, operating personnel must not remove the protective cover. Do not disconnect the Earth connection. Any interruption of the grounding connection can create an electric shock hazard. Before making external connections, always ground the B242 first by connecting the control panel to the ground.

Follow the instructions:

- A)** - Remove the battery power supply; disconnect all connectors and disconnect the Mains/Generator plugs.
- B)** - Push and hold the [ACK-F10] push button and apply the Vdc power supply; all LEDs/Display turn on.
- C)** - Release the button when you have verified all indicators; the LEDs will turn off and the message [- - -] will be displayed.

**NOTE - At this stage of the TEST, if the display indicates one of the codes contained in Table 13.1 or 13.2, the Be242 is damaged and should be returned to Bernini Design.**

**To exit the Troubleshooting, remove the Vdc supply at anytime**

### **13.1 Testing the Push buttons**

**A)** - Push the push buttons on the front panel one by one. The display will show a message according to Table 13.1. As soon as you release all buttons, the message [- - -] will be displayed.

**Table 13.1: Push buttons true table**

Push button	Display Code	Push button	Display Code
[START-F1]	[ F1 ]	[OFF-F7 ]	[ F7 ]
[STOP-F2]	[ F2 ]	[AUTO.]	[auto]
[ I-F3 ]	[ F3 ]	[TEST↑]	[tESt]
[ O-F4 ]	[ F4 ]	[←F8]	[ F8 ]
[ I-F5 ]	[ F5 ]	[F9→]	[ F9 ]
[ MAN-F6 ]	[ F6 ]	[ACK-F10]	[ F10]

### **13.2 Testing the Inputs**

Push and hold the [ACK-F10] button until the message [-in-] appears. Connect, one by one, inputs #9 to #14 to the battery minus. For each input, a code will be displayed according to Table 13.2. If more than one input is connected together (or some of them are in short circuit), the display indicates the messages in sequence.

**Table 13.2**

Terminal number (function)	Display Code	Terminal number (function)	Display Code
#14 (Input 4)	[ inP 4]	#9 (Low fuel)	[ FUEL]
#10 (Input 3)	[ inP 3]	#12 (Temperature)	[ tEMP]
#13 (Input 2)	[ inP 2]	#11 (Oil pressure)	[ oil]
	[	#JH1-JH4 (Emergency)	[ EMER]

**13.3 Testing the Outputs**

- A) - Push the [ACK-F10] push button, for about 10 seconds, until the message [-out] appears.
- B) - Connect a lamp (1..2W) to the output terminals (#2 - #6), as indicated in the wiring diagram. At this stage, if a lamp turns on, the Be242(RB) is damaged and should be returned for service.
- C) - Push a button on the front panel. According to **Table 13.3**, the display should indicate the proper message and the lamp must turn on. If a lamp fails to turn on, the Be242(RB) is damaged and should be returned for service.

**Table 13.3: Outputs true table**

Push button	Display Code	Terminal Output	Push button	Display Code	Terminal Output
[START-F1]	[KG]	L3-KG	[OFF-F7]	USE OHM-METER to check the contact resistance L3-KG and T-KM	
[STOP-F2]	[KM]	T-KM	[DISPLAY-F8]		
[I-F5]	[out 2]	# 5	[OFF-F7]	[FUEL]	# 2
[MAN-F6]	[out 1]	# 6	[DISPLAY-F8]	[StoP]	# 4

**To exit the Troubleshooting, remove the Vdc supply at anytime**

**Section 14.0 BE242 General Specifications**

**Supply Voltage :** 11 Vdc to 33 Vdc. **Protection:** internal 300 mA thermal fuse. **Supply Current:** 50 mA up to 150 mA Vbatt. Measurement Precision Vdc: 1%

**Dimensions:** 224X105 X 68 mm, **Cut-out:** round 56mm min. **Be242RB Dim.:** 195X126 X 70 mm /Rail mount.

**Operating Temperature range:** -30 deg C up to +70 deg C. **Humidity Range:** 5% up to 95% non-condensing.

**Be242 Weight:** 230 gr **Be242RB Weight:** 500 gr **Interconnection Cable:** 1 meter

**General Design:** 89/336 EEC, 89/392 EEC, 73/23 EEC, 93/68 EEC, IEC 68-2-6 **Certification:** CE

**Be242RB Relay Output Characteristics:**

Output Current Rating: 8A . Recommended DC LOAD 1A Max @ 24VDC..

**Mains and Generator Voltage Inputs:** Nominal Voltage: 80 Vac up to 600 Vac (permanent & continuously Ph-Ph)  
Over voltage: 4 KVac for one second. Measurement precision: +/- 1% . Input impedance: 2 Mega Ohm

**Mains and Generator Frequency Measurements:** 30-99Hz, Resolution 0,1Hz, Precision/Accuracy 0,5% .

**Current Transformer Inputs (3-Phases):** 10 / 5 Aac up to 1000 / 5 Aac. Maximum Over Current: 8 Aac for 30 seconds.  
Measurement precision: +/- 5% . Internal resistance: 0.05 Ohm

**Digital Inputs:** Open circuit voltage: 10 /22 Vdc (12 V /24V supply). - Closed circuit current: 15 mA dc max.

**Charger Alternator Monitoring:** Operating 3-33 Vdc. Vdc reading accuracy +/- 2%. Excitation Power: max 3 W

**Hour Run Counter & Timers:** internal Quartz Crystal oscillator 4.91Mhz. Resolution 1 second; precision 0,25%

**Section 15.0 Software Upgrades & Revisions**

Firmware Versions	Date	Description
1.0.01	December 2020	First release
4.0.40	March 2023	Minor bugs corrected

**Section 16.0 Application Notes**

**16.10 - Programming of the Automatic Periodic Test (example: 20 minutes every 7 days)**

- A)** - Enter the 'Program Mode' and set [P.41] to [168] hours (168 hours=7days).
  - B)** - Set [P.42] to [ 20'] and save the programming
  - C)** - Select the AUTO mode
  - D)** - Disconnect the battery and wait for the desired start time (using an external clock reference).
  - E)** - Connect the battery and select the 'AUTO' mode.
- The Be242 will start the engine after the programmed hours. The engine will run OFF-LOAD for 20 minutes. If the Mains fails during the automatic periodic test, the Be242 will transfer the load to the generator.

The Be242 does not use an internal real time clock for the programmed hours ([P.41] setting, table 7.05). The user could experiment with shifting the periodic tests (about some minutes a month). To avoid error accumulation, we recommend the following procedures **(D)** and **(E)** as indicated in section 16.10.

***IMPORTANT NOTICE** If the Vdc voltage supply is removed, the Be242 loses count of the days. When the supply restores, the Be242 starts to count the A.P.T. from zero. To synchronize the periodic start follow the above instructions **(D)** & **(E)**.*

**16.20 - Interfacing an Auto start with Be242 A.T.S Controller**

To use the Be242 as an A.T.S. controller you may connect the FUEL output to the AUTOSTART remote start input via a suitable relay. Program the [P.26] to [oFF]. We recommend that you program the [P.31] to [15] (number of attempts) in order to provide proper time for AUTOSTART to start the engine.

**16.30 - Single Phase operation**

Program the parameter [P.8] with the option '3' as indicated in section 7.01B. Connect the Mains LIVE (phase) to terminals 'S' and 'T'. Connect the NEUTRAL to terminal 'R'. Connect the Generator LIVE (phase) to terminals 'L2' and 'L3'. Connect the Neutral to 'L1'. In this way, the outputs KM and KG will output a 'phase'. This will allow to energize the coils of the contactors (supposed to connect the other side of the coils as indicated in section 18). Connect the current transformer to terminals 'COM' and 'CT1'. Finally, adjust the parameters P4, P5, P9 and P10 (Over/Under Voltage settings) according to your needs.

**16.40 - Maintenance & Rental Timers**

Once a timer expires, the Be242 indicates the [Er.10] on display. To clear the alarm(s), enter the manual mode, push and hold the [ACK-F10] button for at least 20 seconds. You are allowed to modify the programmed Maintenance timer at anytime. Programmable timers are described in section 7, table 7.05A-B (P44, P45 and P46). To restart the Rental Timer, you are required to enter the programming and exit the programming (we recommend that you limit the access to the programming by using a password).

**16.50 - Panel & Gen-set Builders Notes:**

-----

-----

-----

**17.00 - Interfacing Auto Start Module**

You may use the FUEL SOLENOID output relay JA2. You may use RUN PLUS input as feedback. You are in some cases required to increase the attempt numbers to let a reasonable time to the AUTO START module to start the engine, When FUEL SOLENOID shuts down, the AUTO START module will stop the engine.

## **18.0 Typical Application Wiring Diagram**

The following drawing illustrates the recommended wiring diagram of the BE242 kit controller. In making the panel please consider the following information.

- Always consult the international standard IEC 61439-1-2-34-5-6-7 IEC 60529
- Keep a reasonable distance between cables that carry 400V utility power and low-voltage cables committed to controlling the engine. This will avoid problems in case of severe lightning.
- Do not underestimate the maximum operating temperature of the panel. Consider a proper de-rating of the electrical parameters. A wrong calculation of the size of the cables, size of terminal blocks or nominal current of the contactors can produce a dangerous over-heat.
- Always limit the current into the panel, from utility power and generator, according to the AC1 rating of the contactors and according to the size of cables and terminal blocks. In case of a short circuit, when the automatic protections fail, you can trust an additional external overcurrent protection (e.g. circuit breaker). Doing so will preserve the integrity of the panel even in case of a direct short circuit.
- Always protect with the appropriate fuse the cables connected to the battery plus. A short circuit on the battery cable can reach several hundred amps.
- Always use pilot relays connected as close as possible to the engine. This is really important if the panel is far away from the generator.
- We recommend that you use a mechanical interlock and auxiliary electrical interlock on the contactors.
- Before commencing the connection of utility power and generator we recommend that you test 100% the automation of the engine and generator.
- Before connecting the final LOAD (e.g. the building) always make a test using some lamps. In this way, you are sure that all connections are very well done,

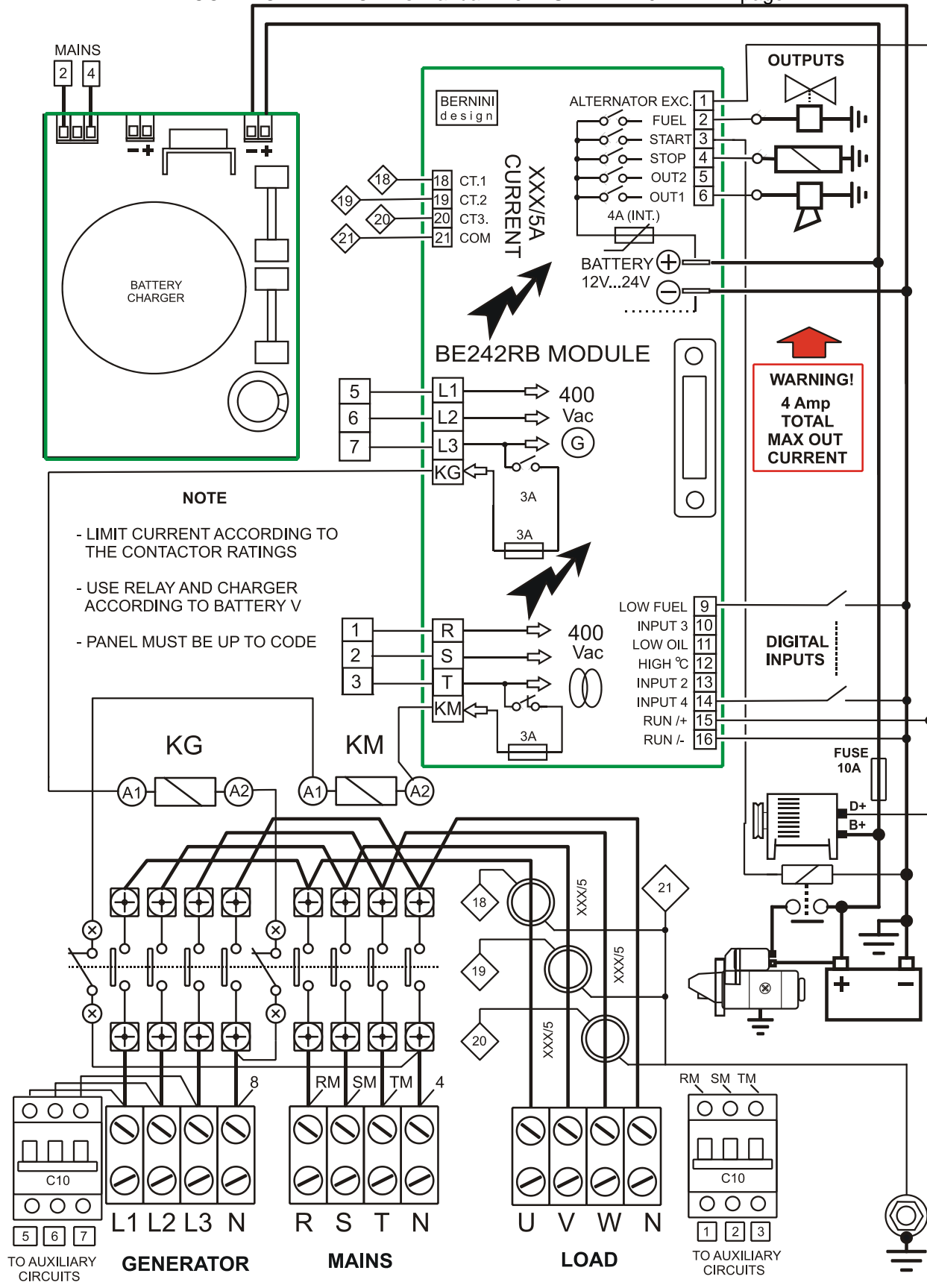



**19.0 Dimensions & Connections**

JA 6-Poles 5mm		JD 8-Poles 5mm		JE 4-Poles 5mm		JF 4-Poles 7.5mm		
1	Alternator Excitement	9	Low Fuel Input	18	Current Trasf. 1	L1	Generator Voltage Input	
2	Fuel Solenoid	10	Input 3	19	Current Trasf. 2	L2		
3	Start Solenoid	11	Low Oil Pressure	20	Current Trasf. 3	L3		
4	Stop Solenoid	12	High Temperature	21	Common CTs	KG	Contact Output	
5	Output 2	13	Input 2	<b>JC SUB-D 25 POLES (cable 1m included in the Be242 kit)</b>			<b>JG 4-Poles 7.5mm</b>	
6	Output 1	14	Input 4				R	Mains
<b>JB Male Faston 6.3mm</b>		15	Running Plus				S	Voltage
7	Battery Plus	16	Running Minus				T	Input
8	Battery Minus					KM	Contact Output	

BE242RB DIMENSIONS

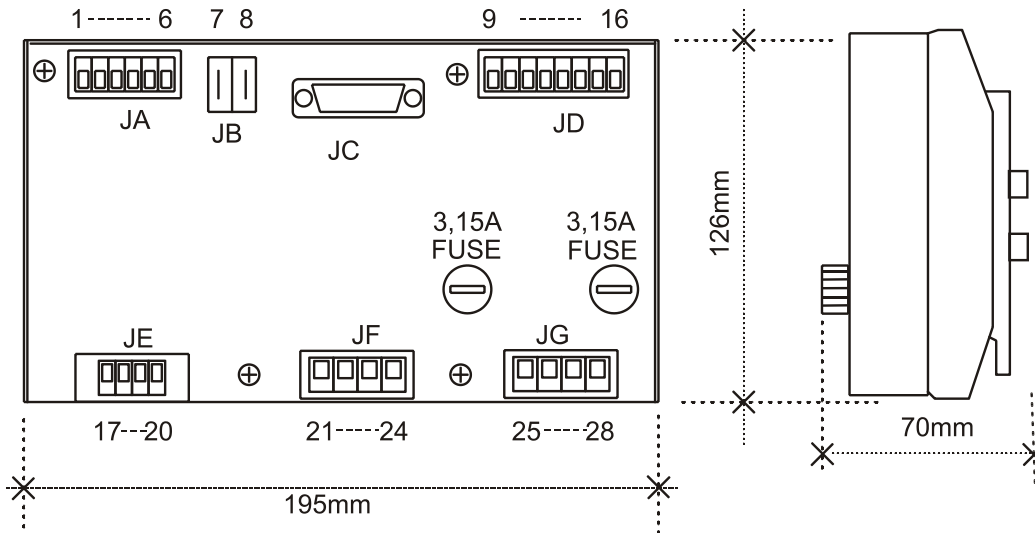

BE242 DIMENSIONS ([DOWNLOAD FOOT PRINT FOR MAKING HOLES](#))

